

ROBOTICS

Product specification

Controller IRC5



Trace back information:
Workspace 23D version a14
Checked in 2023-12-12
Skribenta version 5.5.019

Product specification

Controller IRC5

Design 14

Document ID: 3HAC047400-001

Revision: AK

The information in this manual is subject to change without notice and should not be construed as a commitment by ABB. ABB assumes no responsibility for any errors that may appear in this manual.

Except as may be expressly stated anywhere in this manual, nothing herein shall be construed as any kind of guarantee or warranty by ABB for losses, damage to persons or property, fitness for a specific purpose or the like.

In no event shall ABB be liable for incidental or consequential damages arising from use of this manual and products described herein.

This manual and parts thereof must not be reproduced or copied without ABB's written permission.

Keep for future reference.

Additional copies of this manual may be obtained from ABB.

Original instructions.

© Copyright 2013-2023 ABB. All rights reserved.
Specifications subject to change without notice.

Table of contents

Overview of this product specification	7
1 Description of the IRC5 controller	11
1.1 Controller variants	11
1.1.1 Single cabinet controller	11
1.1.2 Additional drive module	18
1.1.3 IRC5 Panel Mounted Controller	20
1.1.4 IRC5 Compact controller	29
1.1.5 Stacking of IRC5 modules	32
1.1.6 IRC5 as stand alone controller	34
1.1.7 Empty cabinets	37
1.1.8 MultiMove	39
1.1.9 Additional motors	41
1.1.10 External panel	44
1.2 Safety	45
1.2.1 Applicable standards	45
1.2.2 Safety functions	47
1.2.3 Safety data	49
1.3 Installation and maintenance	53
1.3.1 Installation	53
1.3.2 Maintenance	57
1.4 Computer system	59
1.4.1 The IRC5 main computer	59
1.4.2 Communication	61
1.4.3 Memory	63
1.4.4 I/O system	65
1.5 Operator's interface	73
1.5.1 FlexPendant	73
1.5.2 RobotStudio	76
1.5.3 Connected Services	78
1.6 Programming	79
1.6.1 Programming	79
1.6.2 Automatic operation	82
1.6.3 RAPID language and environment	83
1.6.4 Exception handling	84
1.6.5 Robot motion	85
1.7 Additional safety options	89
1.7.1 Electronic Position Switches [810-1]	89
1.7.2 SafeMove [810-2]	90
1.7.3 SafeMove Basic [1125-1] and SafeMove Pro [1125-2]	94
2 Specification of variants and options	103
2.1 Introduction to variants and options	103
2.2 Basic	104
2.2.1 Controller variants	104
2.2.2 Mains connection type	110
2.2.3 Main switch	111
2.2.4 Controller cooling conditions	112
2.2.5 Warranty	116
2.2.6 Connected Services enabled	117
2.3 FlexPendant	118
2.4 Control module	120
2.4.1 PCI options	122
2.4.2 Scalable I/O	126
2.4.3 Conveyor	127
2.4.4 Internal DeviceNet I/O	129

Table of contents

2.4.5	External DeviceNet I/O	130
2.4.6	Power supply	131
2.4.7	Functional Safety	132
	2.4.7.1 Discrete I/O Safety	135
	2.4.7.2 Safety Robot Supervision	136
2.4.8	IMM Interface	138
2.4.9	Operator's interface	140
2.5	Drive module	144
	2.5.1 Drive module options	149
2.6	RobotWare	152
2.7	Floor cables	157
Index		159

Overview of this product specification

About this product specification

It specifies the properties of the IRC5 robot controller in terms of:

- The structure and dimensional prints
- The fulfilment of standards, safety and operating equipment
- RobotWare OS
- I/O system
- Additional motors
- Variants and options

Usage

Product specifications are used to find data and performance about the product, for example to decide which product to buy. How to handle the product is described in the product manual.

Users

It is intended for:

- Product managers and product personnel
- Sales and marketing personnel
- Order and customer service personnel

References

Reference	Document ID
<i>Product specification - Controller software IRC5</i> IRC5 with main computer DSQC1000 (or later) and RobotWare 6.	3HAC050945-001
<i>Product manual - IRC5</i> IRC5 with main computer DSQC1000.	3HAC047136-001
<i>Product manual - IRC5 Compact</i> IRC5 with main computer DSQC1000.	3HAC047138-001
<i>Product manual - IRC5 Panel Mounted Controller</i> IRC5 with main computer DSQC1000.	3HAC047137-001
<i>Operating manual - Service Information System</i>	3HAC050944-001
<i>Product specification - Robot user documentation, IRC5 with RobotWare 6</i>	3HAC052355-001

Revisions

Revision	Description
-	First revision
A	<ul style="list-style-type: none"> • Minor corrections/update • Two new Force Sensor Package added

Continues on next page

Overview of this product specification

Continued

Revision	Description
B	<ul style="list-style-type: none"> Minor corrections/update Option 700-8, Compact controller added. Option 976-1, T10 Jogging device added Option 983-1, Jokab enabling device added
C	<ul style="list-style-type: none"> Added MultiMove.
D	<ul style="list-style-type: none"> The specification is restructured and rewritten to better fit the structure of the specification form.
E	<ul style="list-style-type: none"> Added reference to <i>Application manual - PROFlenergy Device</i>. List of minimum cycles for safety parts added. Minor corrections/update
F	<ul style="list-style-type: none"> Added the functional safety options, see SafeMove Basic [1125-1] and SafeMove Pro [1125-2] on page 94. Added references to manuals for industrial networks (fieldbus). Added IRB 8700. Updated the list of robots supported by SafeMove. Option 1341-1 <i>Vision interface</i> removed from the list of limitations. Option 714-1 <i>RS232 to 422 converter</i> removed from the list of limitations.
G	<ul style="list-style-type: none"> 8700 added to Controller rated power and Line fusing. Table for Interrupt capacity for option 742-1 added. The phrase "System Builder" replaced by "Installation Manager".
H	<ul style="list-style-type: none"> IRB 910SC added to section <i>Installation, Controller rated power and Line fusing</i>. Option "Remote Service" changed name to "Connected Services". Connected Services options 890-4 and 890-5 added to specification. Major structural change in chapter <i>Specification of variants and options</i>. Comments added to SafeMove options in section <i>SafeMove Basic [1125-1]</i> and <i>SafeMove Pro [1125-2]</i>.
J	<p>Published in release R17.1. The following updates are done in this revision:</p> <ul style="list-style-type: none"> IRB 910SC added to section <i>IRC5 Compact controller/Limitations and Power and cooling</i>. Minor changes. Added section <i>Rated voltage and current</i>. Added section <i>Local I/O</i>. Added Resolution data for <i>Force sensor</i>.
K	<ul style="list-style-type: none"> Updated list of applicable standards. Added new options for <i>Functional Safety</i> [997-2], [997-3], and [1241-1]. Added table with values for Short Circuit Current Rating, section <i>Rated voltage and current</i>. Minor changes.
L	<ul style="list-style-type: none"> Correction of information for option PROFIBUS DP Master [969-1] and option PROFIBUS m/s CFG Tool [285-1] Minor changes.
M	<ul style="list-style-type: none"> Added sections Stacking of IRC5 modules on page 32. Updated the information on Connection, Further options.

Continues on next page

Revision	Description
N	<ul style="list-style-type: none"> Minor changes. Removed the phased out options: option Combi 8DIIn/8DOOut 2AnOut [717-2] and option Digital in/8 Relay Out [718-2] Option <i>Conv.Tracking unit Int.</i> [1550-1] is added Option <i>Conv.Tracking unit Ext.</i> [1551-1] is added Removed a phased out option <i>Pre-wiring</i> [890-3] The table for options not available with IRC5 Compact controller is updated
P	Minor changes.
Q	<p>Published in release R18.2</p> <ul style="list-style-type: none"> Changed maximum motion tasks from 6 to 7 in IRC5 as stand alone controller limitation Removed IRB 6660 from PMC Large limitations Added option <i>CIP Safety Scanner&Adap.</i> [997-4] Removed the R18.2 phased out options: <i>External 24V 4A</i> [886-1], <i>Main voltage 3x500V</i> [769-5], <i>GPRS/Internet</i> [890-1], <i>Euromap 12 and SPI AN116</i> [671-1] Removed IRB 260 as a phased out product from R18.2
R	<ul style="list-style-type: none"> Updated Robots supported by SafeMove with a note
S	<p>Published in release 19B</p> <ul style="list-style-type: none"> Removed option <i>T10 Jogging device</i> [976-1] as a phased out option
T	<p>Published in release 19B</p> <ul style="list-style-type: none"> Added update on option <i>Conv.Tracking unit Int.</i> [1550-1] and option <i>Conv.Tracking unit Ext.</i> [1551-1]
U	<p>Published in release 19C</p> <ul style="list-style-type: none"> Removed option <i>Connected Services 3G</i> [890-4] and option <i>Connected Services WiFi</i> [890-5] from IRC5 Compact controller limitations Updated the note on option <i>Conv.Tracking unit Int.</i> [1550-1] and option <i>Conv.Tracking unit Ext.</i> [1551-1]
V	<p>Published in release 19D</p> <ul style="list-style-type: none"> Added FlexPendant available languages Updated the note on option <i>Conv.Tracking unit Int.</i> [1550-1] and option <i>Conv.Tracking unit Ext.</i> [1551-1]
W	<p>Published in release 20A</p> <ul style="list-style-type: none"> Updated Stacking of IRC5 modules on page 32
X	<p>Published in release 20B</p> <ul style="list-style-type: none"> Removed IRB 6620LX as it is phased out Updated the table for options which are not available with IRC5 Compact controller Information regarding priority for EtherNet ports updated in section Ethernet connections on page 60.
Y	<p>Published in release 20C</p> <ul style="list-style-type: none"> Updated option <i>Safety module</i> [996-1] with a note Updated option <i>Underwriters Laboratory</i> [429-1] by adding option <i>Keyless Selector 2</i> [735-8] modes to the requirements Removed option <i>Jokab enabling device</i> [983-1], the option is phased out Updated option <i>FlexPendant 30 m</i> [701-3]
Z	<p>Published in release 20D</p> <ul style="list-style-type: none"> Updated the description of Warranty Updated option <i>Prepared for Motor unit/Gear unit</i> [946-1]

Continues on next page

Overview of this product specification

Continued

Revision	Description
AA	Published in release 21A <ul style="list-style-type: none">• Added option <i>Prep. for 3rd party MU</i> [1389-1]• Updated IMM Interface (Further options)• Changed the name <i>Local I/O</i> to <i>Scalable I/O</i>
AB	Published in release 21C <ul style="list-style-type: none">• PMC Large is available for IRB 390
AC	Published in release 21D <ul style="list-style-type: none">• Updated the chapter <i>Single cabinet - different views</i>.• PROFIBUS DP Master [969-1] phased out.• PROFIBUS DP m/s CFG Tool [285-1] phased out.• Updated safety data.
AD	Published in release 22A <ul style="list-style-type: none">• Updated information about humidity, see Operating requirements on page 53.• Updated Force sensor weight in Force sensor specification chapter.
AE	Published in release 22C <ul style="list-style-type: none">• Updated description for [1389-1] <i>Prep. for 3rd party MU</i>.
AF	Published in release 22D <ul style="list-style-type: none">• Added information about a new version of the FlexPendant.
AG	Published in release 23A <ul style="list-style-type: none">• Updated lists of digital inputs and digital outputs.• Corrected maximum number of allowed I/O units, see I/O system on page 65.• Updated information on limitations for MultiMove on page 39.• Removed option [890-4] <i>Connected Services 3G</i>.
AH	Published in release 23B <ul style="list-style-type: none">• Removed SafeMove2 limitation for <i>Panel Mounted Controller</i>.• Information about options for Integrated Vision removed. For detailed descriptions of the options and related hardware, see Product specification - Integrated Vision.
AJ	Published in release 23C <ul style="list-style-type: none">• IRB 120 is phased out from release 23C.• Added IRB 1510 new values.
AK	Published in release 23D <ul style="list-style-type: none">• Added option <i>Connected Services 4G EU</i> [890-6].• Added option <i>Connected Services 4G US</i> [890-7].• IRB 910 SC is phased out from release 23D.• IRB 1410 is phased out from release 23D.

1 Description of the IRC5 controller

1.1 Controller variants

1.1.1 Single cabinet controller

General

The IRC5 controller contains the electronics required to control the manipulator, additional axes and peripheral equipment.

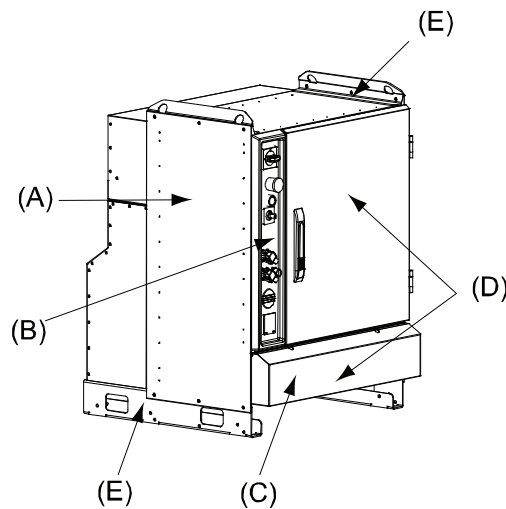

xx130000791

Pos	Name	Description
A	Controller color	Aluzink
B	Operator's panel	
C	Connector covers	All cable connections at the front, optional covered
D	Controller color, door and connector covers	NCS 2502 B (light grey)
E	Controller color, feet and lifting eyes	Black

Modular design

The IRC5 has a modular design, and can be divided into two modules:

- The drive module, containing the drive system.
Up to three additional drive modules can be connected. For more information, see [Additional drive module on page 18](#) and [MultiMove on page 39](#).
- The control module, containing the control system.
For example the main computer (including one PCIe slot for extension boards), operator's panel, the mains switch, communication interfaces, FlexPendant connection, service ports and some space for customer equipment, for example ABB I/O boards.

The controller also contains the system software, RobotWare-OS, which includes all basic functions for operation and programming, as described further on in this

Continues on next page

1 Description of the IRC5 controller

1.1.1 Single cabinet controller

Continued

chapter. On top of RobotWare-OS it is possible to install a number of options with additional functionality. For description of these options, please see *Product specification - Controller software IRC5*.

Single cabinet controller

The content described above is normally mounted into one single cabinet. The single cabinet offers a compact solution suitable for most applications where there is less need for additional equipment inside.

Additional IRC5 variants

Two additional IRC5 variants are available

- IRC5 Panel Mounted Controller, where the integrator takes care of the encapsulation, see [IRC5 Panel Mounted Controller on page 20](#)
 - IRC5 Compact controller, a small footprint controller available for the smaller IRBs, see [IRC5 Compact controller on page 29](#).
-

Cabinet data

Data	Weight
Single cabinet controller	max 150 kg
Empty cabinet large	42 kg

Data	Volume (H x W x D)
Single cabinet controller	970 x 725 x 710 mm
Empty cabinet large	

For information on ordering empty cabinets, see [Empty cabinets on page 37](#).

Airborne noise level

Airborne noise level	Description
Sound pressure level outside	< 70 dB (A) Leq (acc. to the working space Machinery directive 2006/42/EG)

Continues on next page

1 Description of the IRC5 controller

1.1.1 Single cabinet controller

Continued

Single cabinet - different views

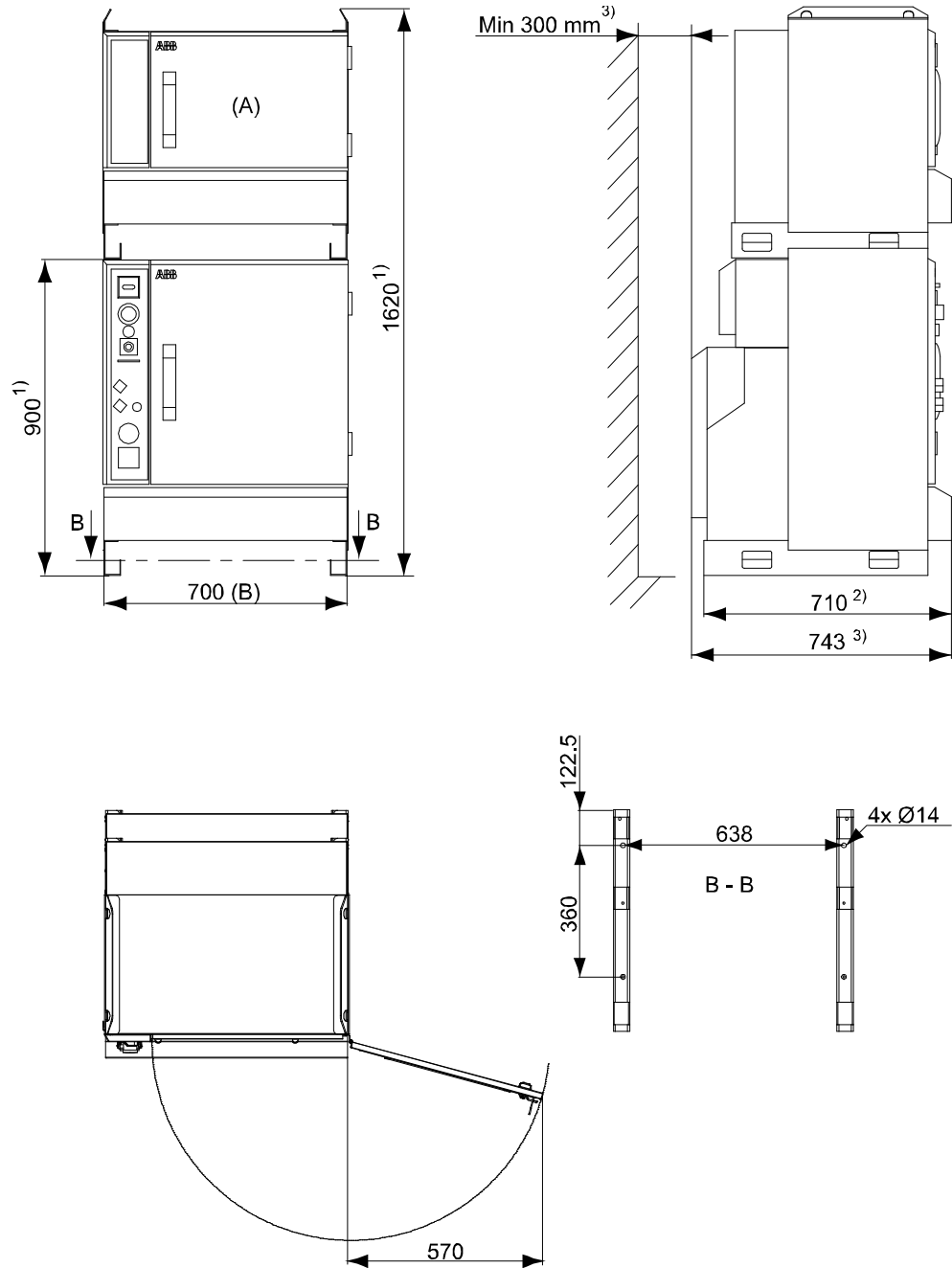

xx0900000930

Pos	Description
A	Optional process module for Single cabinet controller
B	725 for build in

Pos	Description
1	For wheel option, add 10 mm to the height
2	For service access to the rear, add 250 mm to the depth
3	Optional moist dust filter

Continues on next page

1 Description of the IRC5 controller

1.1.1 Single cabinet controller

Continued

The below picture shows the single cabinet with the large cabinet on top.

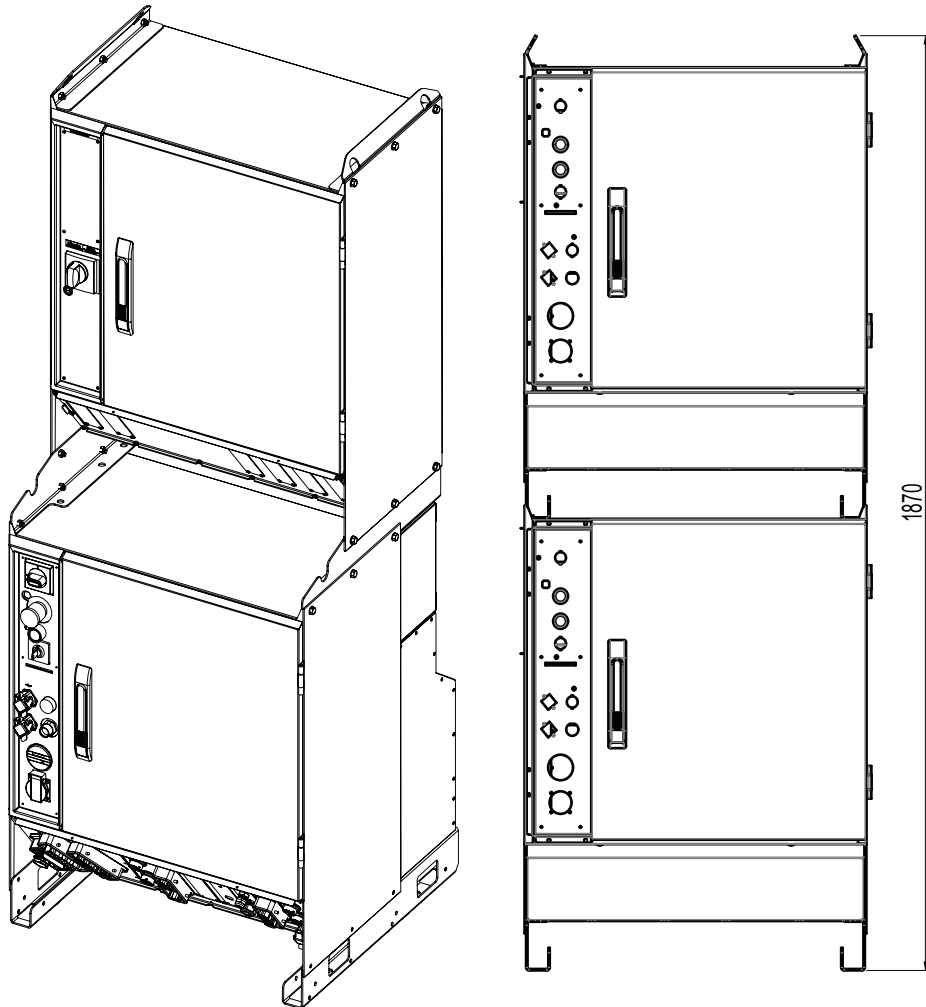

xx2100002521

Height = 1870mm (Cabinet with lifting beam 970mm, cabinet without lifting beam 900mm)

Continues on next page

Operator's panel

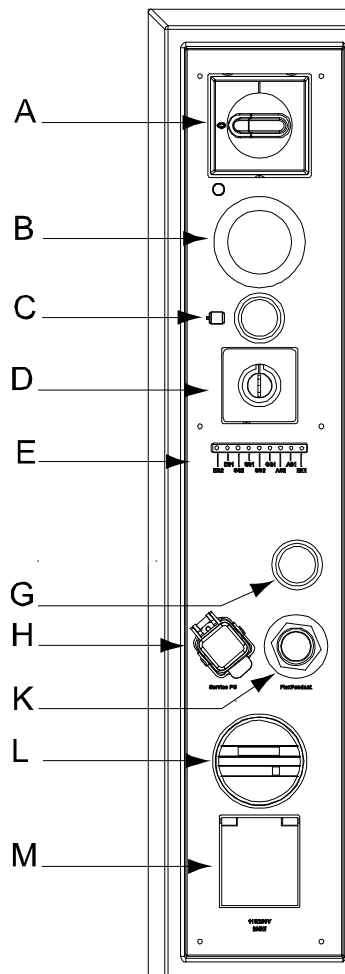

xx0900000933

Pos	Name
A	Mains switch and remote control of power to Drive modules
B	Emergency stop - if pressed in, turn to release
C	MOTORS ON
D	Operating mode selector
E	Safety chain LEDs (option)
G	FlexPendant Hot Plug pushbutton (option)
H	Service PC connection
K	FlexPendant connection
L	Duty Time Counter (option)
M	Service outlet 115/230V, 200W (option)

Continues on next page

1 Description of the IRC5 controller

1.1.1 Single cabinet controller

Continued

Cabinet connectors

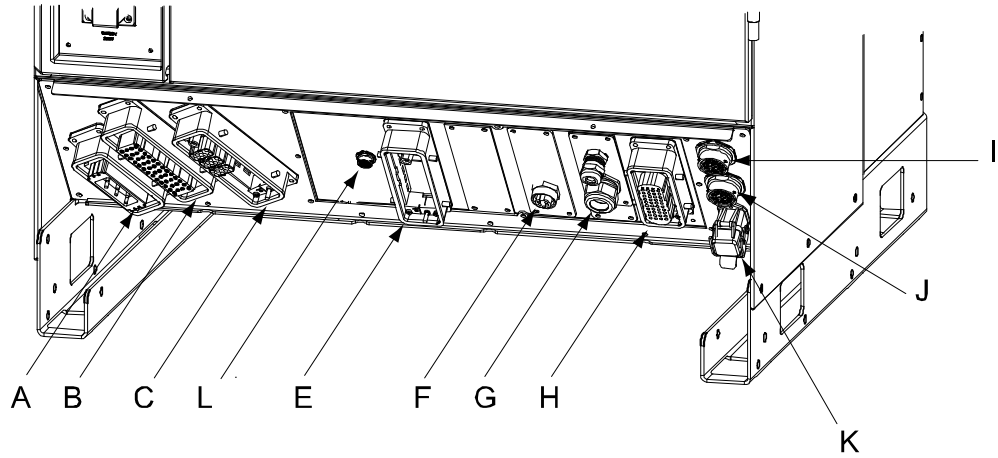

xx0900000980

Pos	Description
A	Power inlet, option 752-2
B	Manipulator motor cable
C	Power to additional motors, XS101
E	Floor cables for manipulator custom power and signals
F	DeviceNet™ on front, option 730-1 and Connected Services antenna connector
G	Cable glands for external operator's panel
H	External connection of safety signals, option 731-2
I	To SMB for additional motors XS41
J	Manipulator SMB cable
K	LAN Ethernet RJ45 on connector plate, option 707-1
L	Ethernet M12 on connector plate, option 906-1

Connector parts additional motors

The controller can include, in addition to drive system for a 4-6 axes robot, equipment to control up to three additional motors. The connection to additional motors is collected in one industrial connector type Harting Han-Modular® (XS101), see [Cabinet connectors on page 16](#).

When ABB motors or positioners are ordered, the connector is included with the cabling. For other cases, find part numbers in table below.

Pcs	Part	Harting part No.	Miltronic part No.
1	Cable gland		52 01 5700
1	Hood	09 30 024 0531	
1	Hinged frame for 6 modules	09 14 024 0313	
2-3	Dummy module	09 14 000 9950	
2-3	6 pole module	09 14 006 3001	
2	12 pole module	09 14 012 3001	

Continues on next page

1 Description of the IRC5 controller

1.1.1 Single cabinet controller

Continued

Pcs	Part	Harting part No.	Miltronic part No.
<15	Pin	09 15 000 6101	
<15	Pin	09 33 000 6107	
<10	Pin	09 15 000 6106	

1 Description of the IRC5 controller

1.1.2 Additional drive module

1.1.2 Additional drive module

General

Additional drive modules can be ordered together with the single controller to control additional axes or additional robots, MultiMove.

Up to three additional axes can be controlled by each drive module, and up to three additional drive modules can be connected. For more information see [MultiMove on page 39](#).

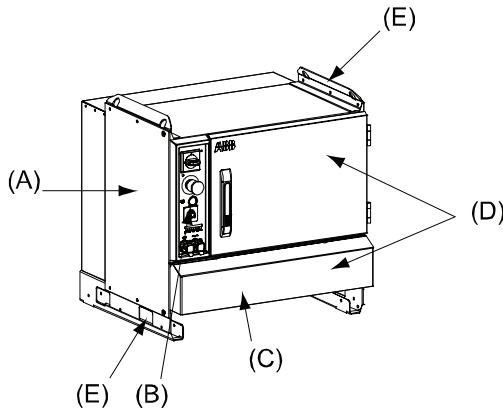

xx1500000255

Pos	Name	Description
A	Controller color	Aluzink
B	Operator's panel	
C	Connector covers	All cable connections at the front, optional covered
D	Controller color, door and connector covers	NCS 2502 B (light grey)
E	Controller color, feet and lifting eyes	Black

Cabinet data

Data	Weight
Drive module	100-130 kg
Empty cabinet small	35 kg

Data	Volume (H x W x D)
Drive module	720 x 725 x 710 mm
Empty cabinet small	

For information on ordering empty cabinets, see [Empty cabinets on page 37](#).

Continues on next page

Operator's panel

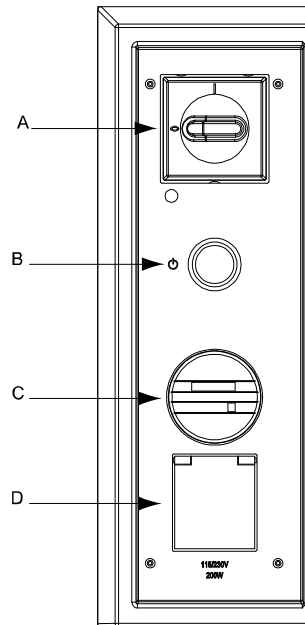

xx0900000935

Pos	Description
A	Mains isolator switch.
B	Stand by lamp indicates that electronic supply is switched on by the Control Module mains switch.
C	Duty Time Counter (option) accumulates the hours (up to 99999.99 h) when the motors are in operation and the brakes are released.
D	Service outlet 115/230V, 200W (option)

1 Description of the IRC5 controller

1.1.3 IRC5 Panel Mounted Controller

1.1.3 IRC5 Panel Mounted Controller

General

The IRC5 Panel Mounted Controller (PMC), is a concept where the controller can be mounted in a customer cabinet for example when there are special demands on size reduction or hygienic encapsulation. For MultiMove applications the robot can be ordered with only the drive module. Two versions of Panel Mounted Controller are available, depending on robot version and size, PMC Small and PMC Large. The difference is the size of drive units in the Drive module.

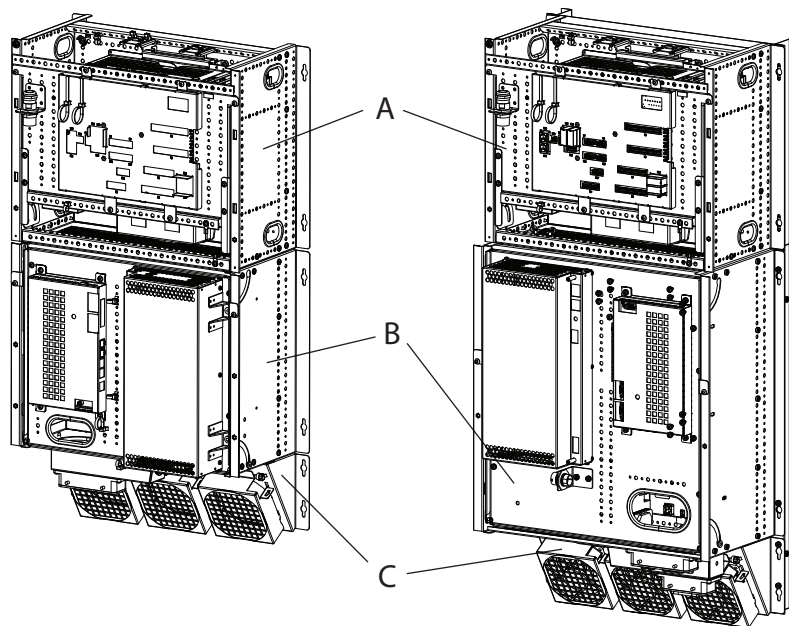

xx1100000484

Pos	Description
A	Control Module
B	Drive Module (different design for PMC small and PMC large)
C	Fan unit (for PMC large this is a part of the Drive Module)

The modules have to be encapsulated by the customer to at least protection class IP54 according to IEC 60529. The modules are delivered in class IP20. The supplied cabling between the modules is long enough to allow side-by-side mounting or back-to-back as an alternative to the vertical mounting as shown in the pictures. For MultiMove applications an additional robot's Drive module can be mounted below the main robot's Drive module. For further separation, customized solution is possible. The cabling consists of one standard shielded Ethernet cable and one safety interlocking cable. The required connectors are of type Molex Micro-Fit 8 and 10 pole art. no. 43025, socket art. no. 43030.

Air channel for PMC large

For PMC large, there is an air channel that is mounted behind the controller modules. Make sure that the air can flow freely in the air channel behind the controller as well as through the controller.

Continues on next page

If the Control Module is mounted separately, it can be mounted without the air channel. If it is mounted on top of the Drive Module, it must be mounted on the air channel so it does not obstruct the air flow.

The air flow

The fan to the right creates an air flow through the air channel behind the controller, where the brake resistor bleeder is located. The two fans to the left create an air flow through the controller modules.

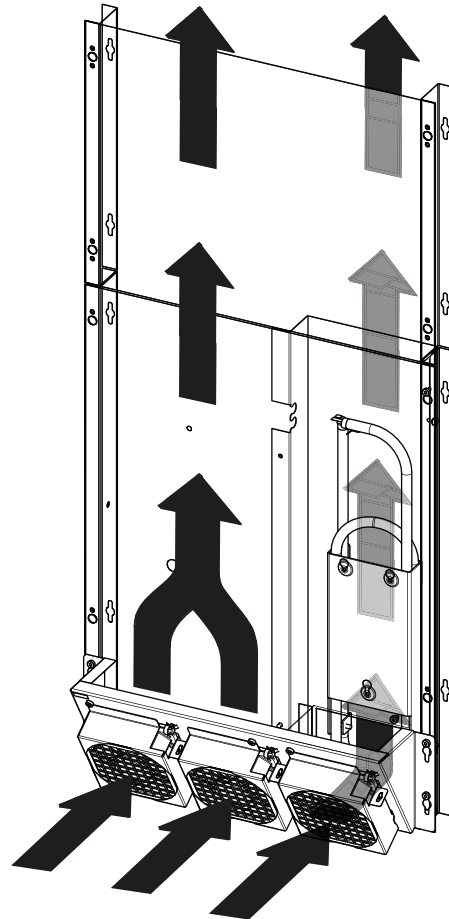

xx110000537

Limitations

Following IRB robots are available with Panel Mounted Controller.

PMC Small available for:

- IRB 360
- IRB 1200
- IRB 1600

PMC Large available for:

- IRB 2400
- IRB 2600
- IRB 4400
- IRB 4600

Continues on next page

1 Description of the IRC5 controller

1.1.3 IRC5 Panel Mounted Controller

Continued

- IRB 66XX
- IRB 6700
- IRB 7600
- IRB 460
- IRB 660
- IRB 760
- IRB 390

Drive units for additional motors can not be installed.

Standards that concern electrical installation and encapsulation have to be addressed by the customer

Regarding the EU Machinery Directive, the Panel Mounted Controller is designed to fulfill the requirements when mounted in an integrator encapsulation.

The Panel Mounted Controller is UL Recognized as standard (UR labelled). However, certain options have to be selected in a proper way. Examples are Safety lamp on the manipulator arm and 2-mode operation mode selector.

The motor cable is to be connected to industrial connector on the drive module.

The following options are not available with Panel Mounted Controller:

Option	Description
429-1	UL/CSA (the PMC is UL recognized)
129-1	Prepared for CE and China (the mains filter is standard)
752-x	Mains connection type
742-x	Mains switch
743-1	Circuit breaker for rotary switch
744-1	Door interlock
708-x	Room temperature (customer internal cabinet air max. 45 °C)
764-1	Air filter
741-x	Cabinet connector cover
707-1, 906-1	Ethernet on connector plate
716-726	Internal I/O and gateway units
727-x	24V 8/16A
730-1	DeviceNet™ on connector plate
731-2	Safety external connector (internal 731-1 included)
671-673	IMM interface
733-1	Operator's panel on cabinet
737-1	Status LEDs on front
907-1	Drives for additional axes
757	SMB for additional axes
761-x	Extension cables between modules
767-1	Duty Time Counter
758-1	Wheels

Continues on next page

1 Description of the IRC5 controller

1.1.3 IRC5 Panel Mounted Controller

Continued

Option	Description
736-x	Service outlet
768-x	Empty cabinet
715-1	Installation kit
810-1	EPS
810-2	SafeMove
922-1	Prepared for IRBP
946-1	Prepared for MU&GU
981-1	Prepared for IRBT

Furthermore, options intended for arc welding applications are not available together with Panel Mounted Controller.

Installation

Space requirement according to Figure 19. For detailed installation information see *Product manual - IRC5 Panel Mounted Controller*.

Dimensions for PMC small

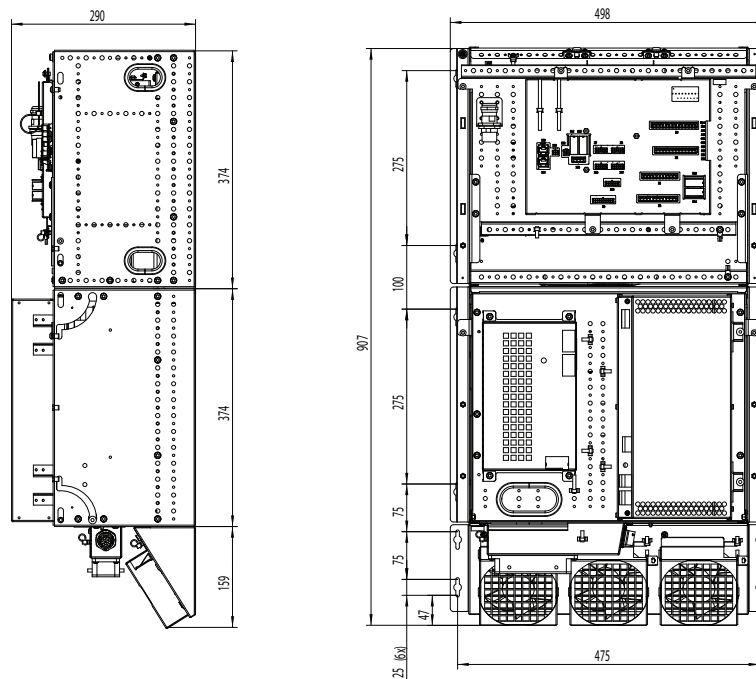

xx0600003314

Continues on next page

1 Description of the IRC5 controller

1.1.3 IRC5 Panel Mounted Controller

Continued

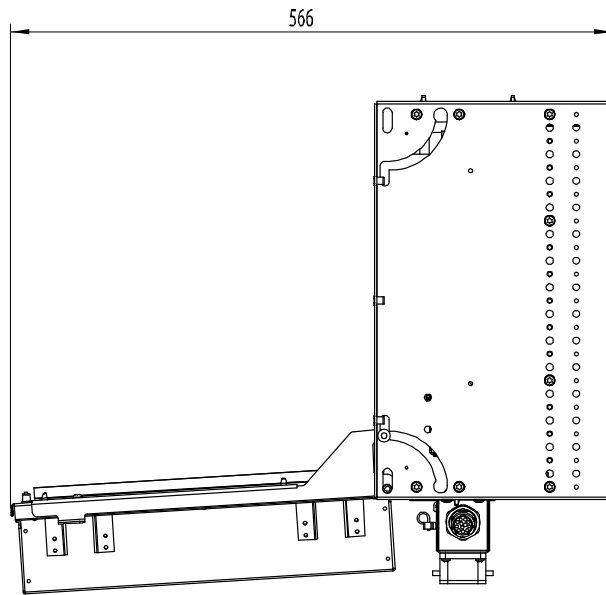

xx070000031

Pos	Description
A	FlexPendant connection if no remote panel

Dimensions for PMC large

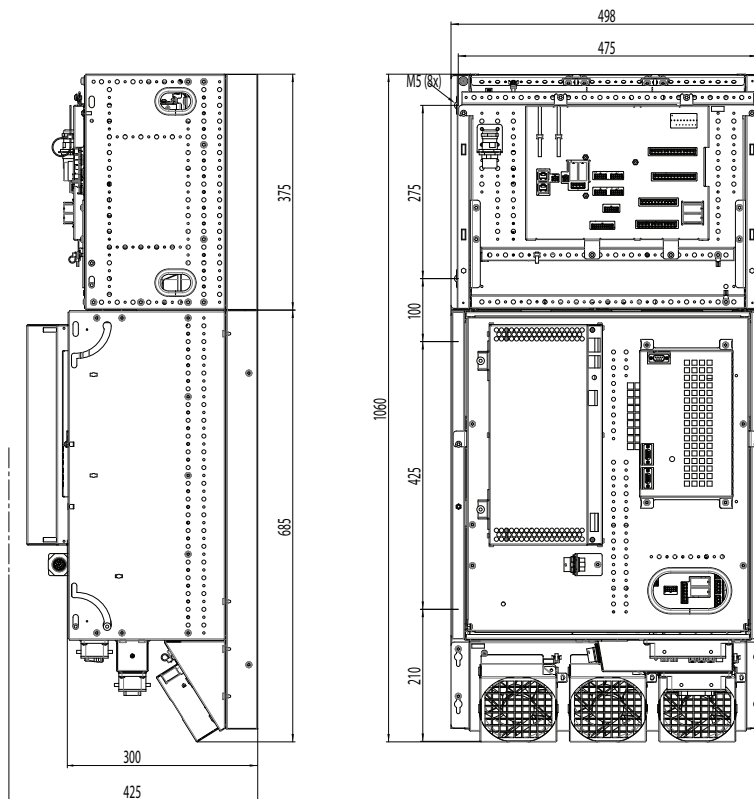

xx110000533

Continues on next page

1 Description of the IRC5 controller

1.1.3 IRC5 Panel Mounted Controller

Continued

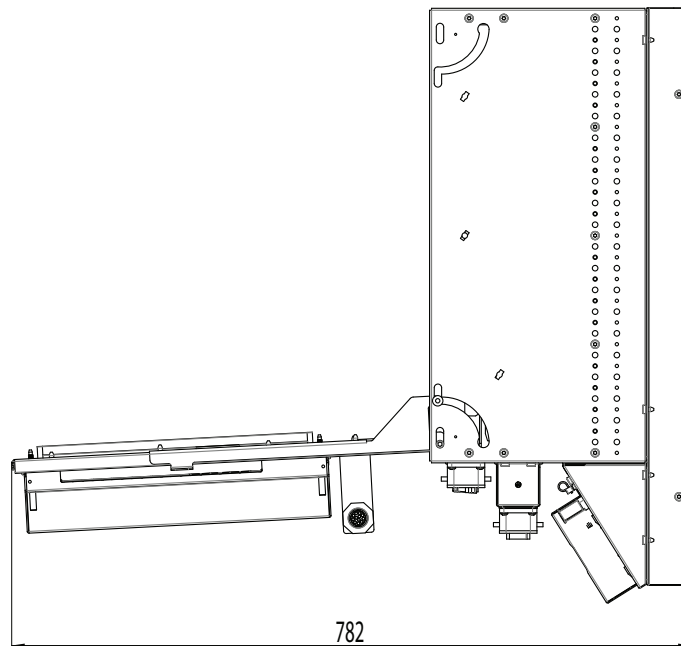

xx110000534

Dimensions for transformer

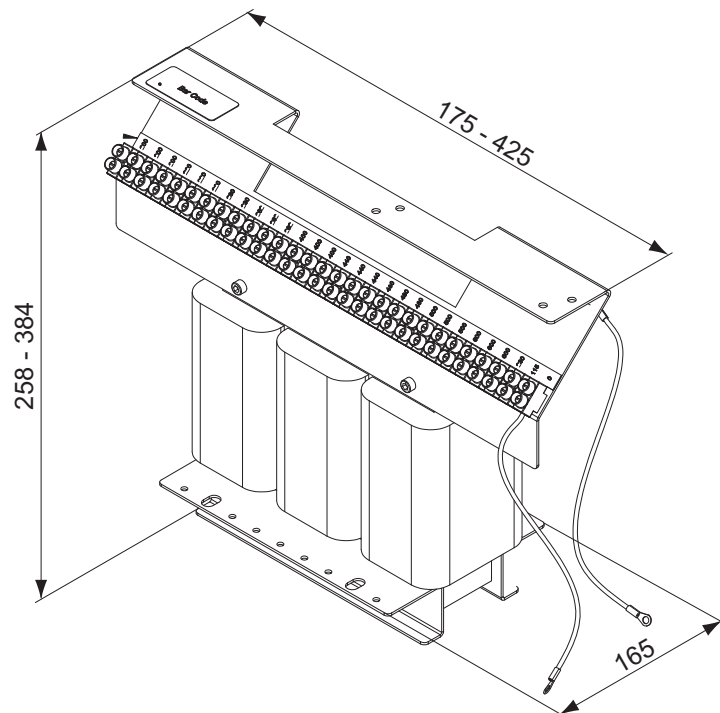

xx090000952

Continues on next page

1 Description of the IRC5 controller

1.1.3 IRC5 Panel Mounted Controller

Continued

Dimensions for inductor (only used with PMC Large)

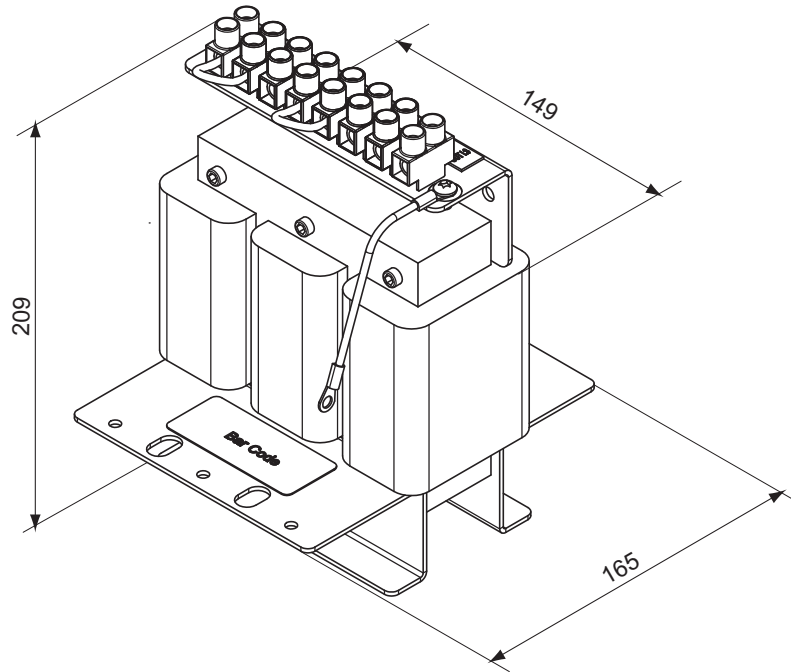

xx110000561

Dimensions for line filter

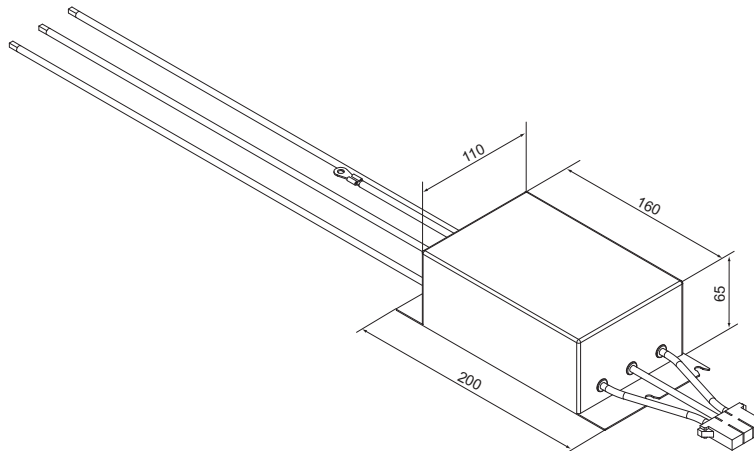

Continues on next page

Dimensions for external operator's panel

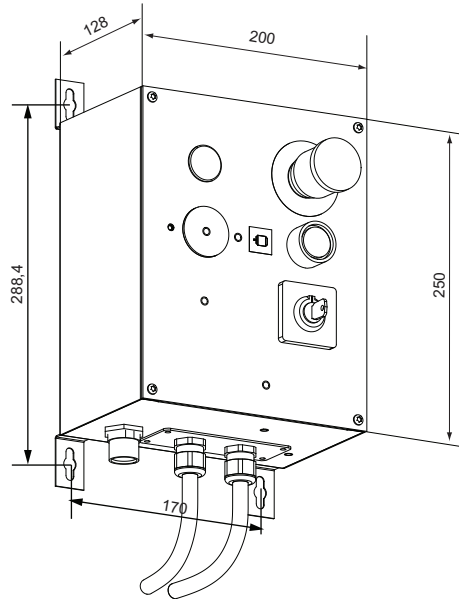

Weight

- Control module 12 kg
- Drive module Small 24 kg
- Drive module Large 40 kg
- Transformer 13-35 kg
- Fan unit 0.5 kg
- Inductor for Drive module large 5 kg
- External Operator panel 3 kg

Power and cooling

For PMC Small, a 4 kVA transformer is included. For PMC Large with 400-480 V, a single phase transformer is included. The transformer comes with rotary mains switch and secondary fuses.

Also the PMC drive module only, option 700-6 intended for MultiMove, includes a transformer.

For PMC Large a fan unit for internal cooling is included in the controller delivery, the unit force cooling air through the drive module and bleeder resistor. For PMC Small the fan unit is optional.

For calculation of the enclosure temperature rise, the dissipated heat has to be known. Since most of the heat depends on the robot motion, the robot program again is dimensioning, With the above 50 % duty cycle, the generated heat is approximately:

Robot type	Heat
IRB 1200	300 W
IRB 1600	300 W
IRB 2400	500 W

Continues on next page

1 Description of the IRC5 controller

1.1.3 IRC5 Panel Mounted Controller

Continued

Robot type	Heat
IRB 2600	500 W
IRB 360	700W
IRB 4400	700 W
IRB 460	700 W
IRB 4600	700 W
IRB 660	1000 W
IRB 6620	1000 W
IRB 6640	1000 W
IRB 6700	1000 W
IRB 760	1000 W
IRB 7600	1500 W

1.1.4 IRC5 Compact controller

General

The IRC5 Compact controller is a desktop sized robot controller designed for segments such as 3C market. The compact controller protection degree is class IP20, according to IEC60529.

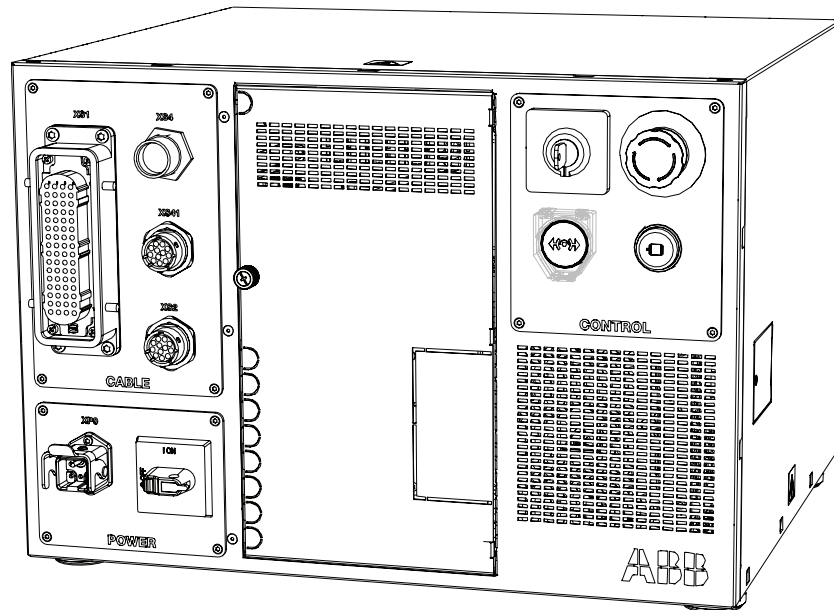

xx0900000316

Limitations

The IRC5 Compact controller is available with the following IRBs:

- IRB 360 ¹
- IRB 1200 ¹
- IRB 1510 ¹
- IRB 1600 ¹

¹ Max axis speed limited due to 1 phase 220/230 V. See the product specification for the respective robot.



Note

MultiMove is not possible.

In the IRC5 Compact controller there is only room to mount one I/O unit (DSQC 652) inside the cabinet.

The following options are not available with IRC5 Compact controller:

Option	Description
129-1	Prepared for CE and China (the mains filter is standard)
604-X	MultiMove
671-673	IMM interface
702-2	Hot plug (for FlexPendant)

Continues on next page

1 Description of the IRC5 controller

1.1.4 IRC5 Compact controller

Continued

Option	Description
707-1, 906-1	Ethernet connector plate
708-2	Room temperature 52C (Max temp, 45C is std)
715-1	Installation kit
717-726	Internal I/O and gateway unit (16in/16out is std)
727-x	24V 4/8 16A (24V 4A for external mounting is available)
728-1	DeviceNet 24V 4Amps
730-1	DeviceNet™ on connector plate
731-X	Safety Connection
733-1	Panel on Cabinet
735-X	Key switch
736-X	Service outlet
737-1	Status LEDs on front
741-1	Cabinet connector cover
742-3	Flange disconnect (rotary switch is std)
743-1	Circuit breaker
744-1	Door interlock
752-x	Mains connection type
753-766	Drives for additional axes
757-x	SMB for additional axes
758-1	Wheels
761-x	Extension cables between modules
764-x	Cooling air filter
767-1	Duty Time Counter
768-X	empty cabinet
769-x	Mains voltage
810-1	Electronic Position Switches
810-2	SafeMove
881-2	PMC without transformer and circuit breaker
882-x	Fans
981-1	Prepared for IRBT
901-1	Dispensepack support
902-1	Channel support
906-1	Ethernet connector plate
907-X	Additional drive
922-1	Prepared for IRBP
931-1	World transformer
941-1	Ethernet switch
946-1	Prepared for MU/GU 757-X SMB for additional axes

Continues on next page

1 Description of the IRC5 controller

1.1.4 IRC5 Compact controller

Continued

Option	Description
1003-1	Drive interface
1541-1	Base Dig. 16In/16Out
1542-1	Add-on Dig. 16In/16Out
1543-1	Add-on Analog 4In/4Out
1544-1	Add-on Relay 8In/8Out
1170-1	Temperature sensor fans
	All Arc welding related hardware options

Dimensions

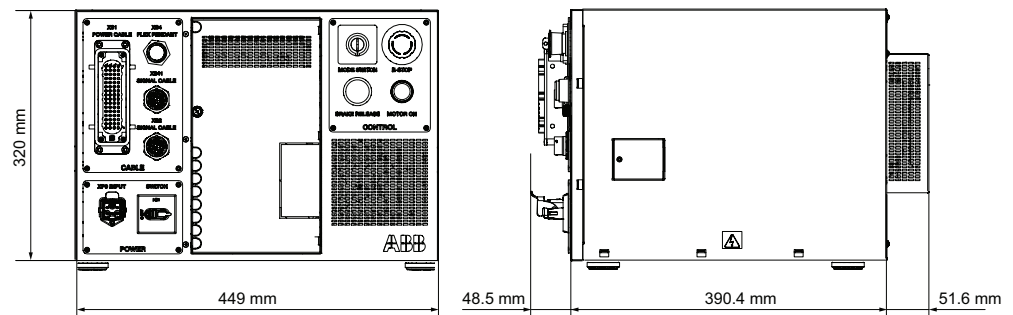

xx1400002103

Weight 28.5 kg

Power and cooling

For calculation of the enclosure temperature rise, the dissipated heat has to be known. Since most of the heat depends on the robot motion, the robot program again is dimensioning, With the above 50 % duty cycle, the generated heat is approximately:

Robot type	Heat
IRB 1200	300 W
IRB 1600	300 W
IRB 360	700 W

1 Description of the IRC5 controller

1.1.5 Stacking of IRC5 modules

1.1.5 Stacking of IRC5 modules

General

The mechanical structure allows IRC5 modules to be mounted in several combinations. For stability reasons the pile should, however be limited to approx 2m in height. Optional wheels are permitted in all combinations as shown.

IRC5 module variants

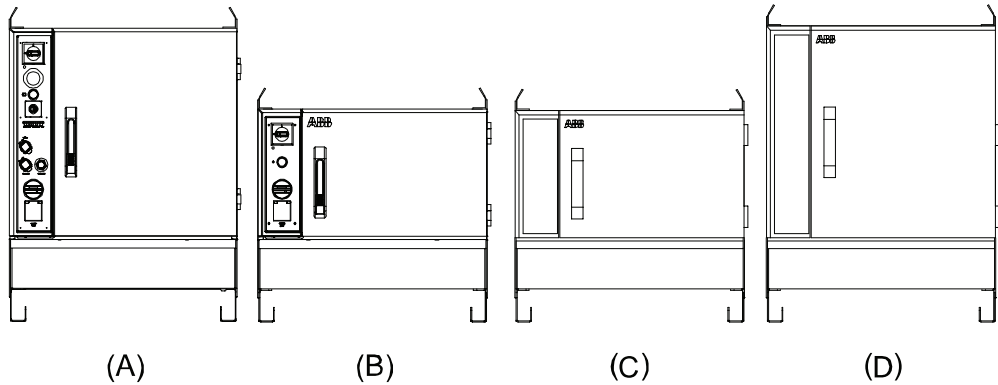

xx1700001403

Pos	Description
A	Single cabinet, H = 970 mm
B	Drive module H, = 720 mm
C	Empty cabinet small H, = 720 mm
D	Empty cabinet large H, = 970 mm

Examples of customer combinations

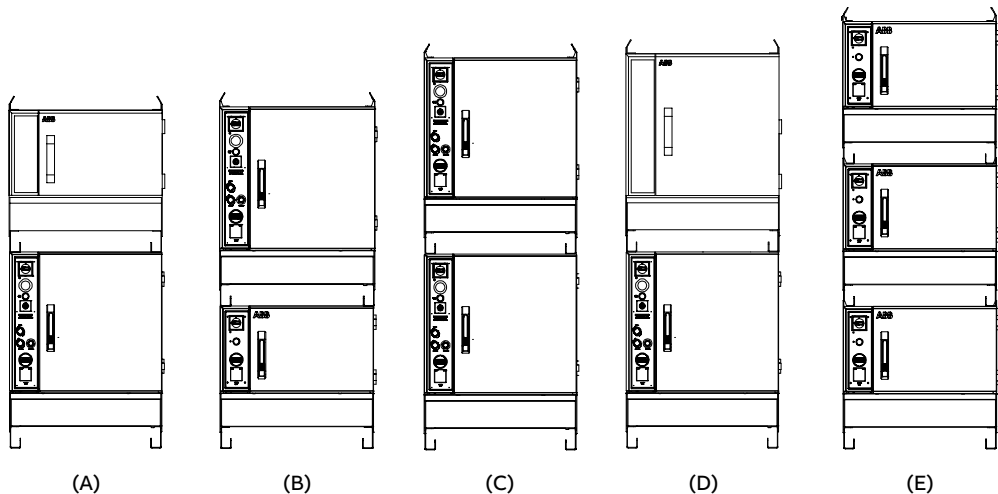

xx1700001380

Pos	Description
A	Single cabinet and Empty cabinet small, H = 1620
B	Drive module and Single cabinet, H = 1620

Continues on next page

1 Description of the IRC5 controller

1.1.5 Stacking of IRC5 modules

Continued

Pos	Description
C	Two Single cabinets, H = 1870
D	Single cabinet and Empty cabinet large, H = 1870
E	Three Drive modules, H = 2020

1 Description of the IRC5 controller

1.1.6 IRC5 as stand alone controller

1.1.6 IRC5 as stand alone controller

General

The IRC5 offers the capability to control a wide range of mechanical devices, additional axes and peripheral equipment. Thereby it is possible to gain from ABB motion technology (including MultiMove) plus an extensive range of other controller features, also for non-ABB manipulators.

Linear mechanical units

Linear mechanical devices, for example gantries, consist of up to three linear main axes and up to three rotating wrist axes. These configurations are supported by kinematic models.

The kinematic model describes the relation between motor rotations and the movement of the TCP (Tool Center Point), thus enabling geometric programming and interpolation, making programming easier and faster.

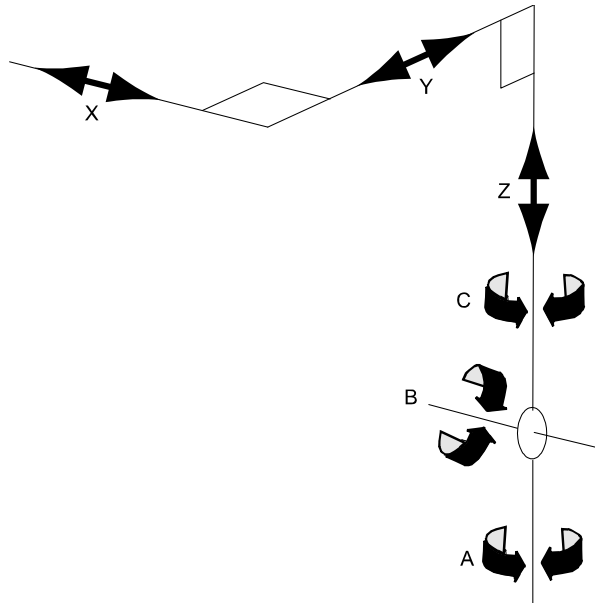

xx0900000950

Arbitrary mechanical units

For arbitrary types of mechanical units, such as loaders, conveyors etc., it is often useful and sufficient to apply joint level control (also when the unit consists of multiple axes). In this case, the benefits of a kinematic model are obviously not available.

Continues on next page

ABB manipulators



Note

Information to consider when ordering a Stand alone Controller for Controller Upgrade.

The controller is delivered from factory with the latest available software and hardware revisions. Depending on which manipulator the controller will be connected to the license key may need to be updated. Above is always applicable when selecting option "NO IRB Manipulator", but also for some specific robot models.

If new license key or new options are needed, these are ordered from Robotics Aftersales via Business Online according to current price list. See prices in Business Online. For questions concerning orders to Robotics Aftersales, submit via RobDesk in Service Portal as Spare part/Order Question.

It is possible to exchange earlier ABB controllers connected to ABB IRB manipulators, thus benefitting from the latest control system technology. The earlier manipulators covered by the 3 phase variants of IRC5 are:

- IRB 140 M2000
- IRB 1400 M98 and M2000
- IRB 2400 M98A and M2000
- IRB 4400 M98A and M2000
- IRB 340 M98 and M2000
- IRB 6600 M2000
- IRB 7600 M2000
- IRB 6400R M99 and M2000 (200/2.5 and 200/2.8)

Motor and drive system selection

The procedure for choosing a stand alone IRC5 drive system is similar to that used for additional motors, see [Additional motors on page 41](#).



Note

For more information on motors and measurement system, see *Product specification - Motor Units and Gear Units* and *Application manual - Additional axes and standalone controller*.

Limitations

The number of axes and mechanical units are limited as follows.

For systems without MultiMove:

- One single motion task
- Maximum 12 axes (located in 1 or 2 drive modules)
- Maximum 1 TCP robot

Continues on next page

1 Description of the IRC5 controller

1.1.6 IRC5 as stand alone controller

Continued

- Maximum 6 additional axes (which can be grouped in an arbitrary number of mechanical units)

Note 1: A TCP robot is a robot equipped with a kinematic model, which is programmed in x, y, z coordinates of the TCP, plus tool orientation. An IRB manipulator is an example of a TCP robot.

Note 2: Without MultiMove, semi-independent programming of individual mechanical units/axes can be achieved through the option 610-1 Independent Axis. Normally, MultiMove is preferred when independent programming is desired.

For systems with MultiMove:

- Maximum 7 motion tasks
- All the non-MultiMove limitations above apply per task
- Maximum 4 TCP robots in total
- Maximum 4 drive modules (that is maximum 32-36 axes)

Note: It is perfectly possible to mix control of IRB manipulators and non-ABB units in the same system.



Note

Since non-ABB manipulators are controlled without the support of a dynamic model, certain limitations apply, for example:

- Only limited QuickMove™ and TrueMove™
- No automatic adaption to vary load conditions
- No Load Identification
- No Collision Detection
- No Absolute Accuracy

1.1.7 Empty cabinets

Empty cabinet small [768-1]

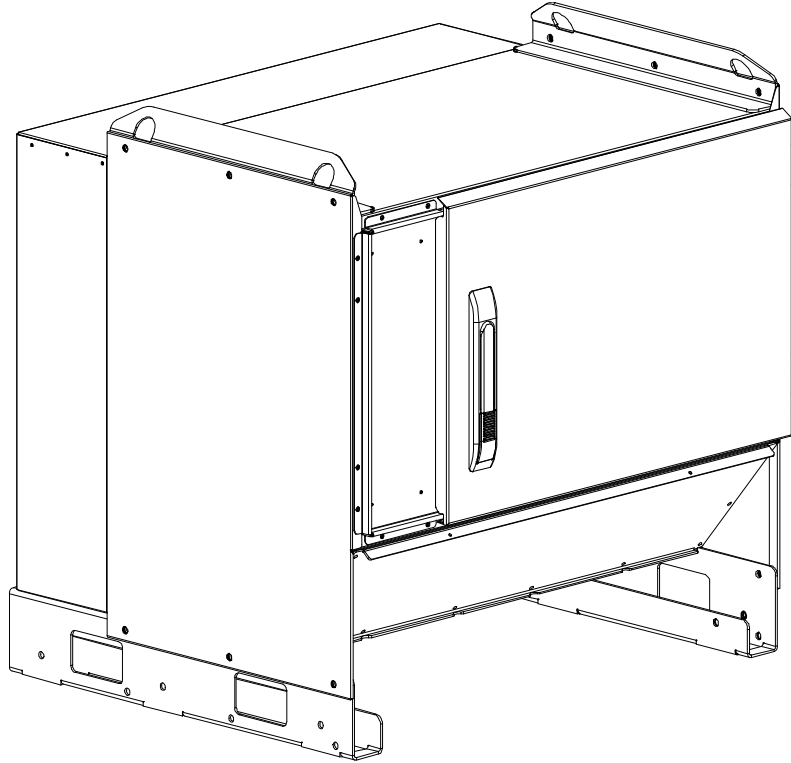

xx090000977

This option is intended for customer equipment or extended use of I/O units.

Mounting plate dimensions (HxW): 511 x 660 mm.

Mounting depth (D): 250-325 mm

For cabinet dimensions see [Cabinet data on page 18](#).

Continues on next page

1 Description of the IRC5 controller

1.1.7 Empty cabinets

Continued

Empty cabinet large [768-2]

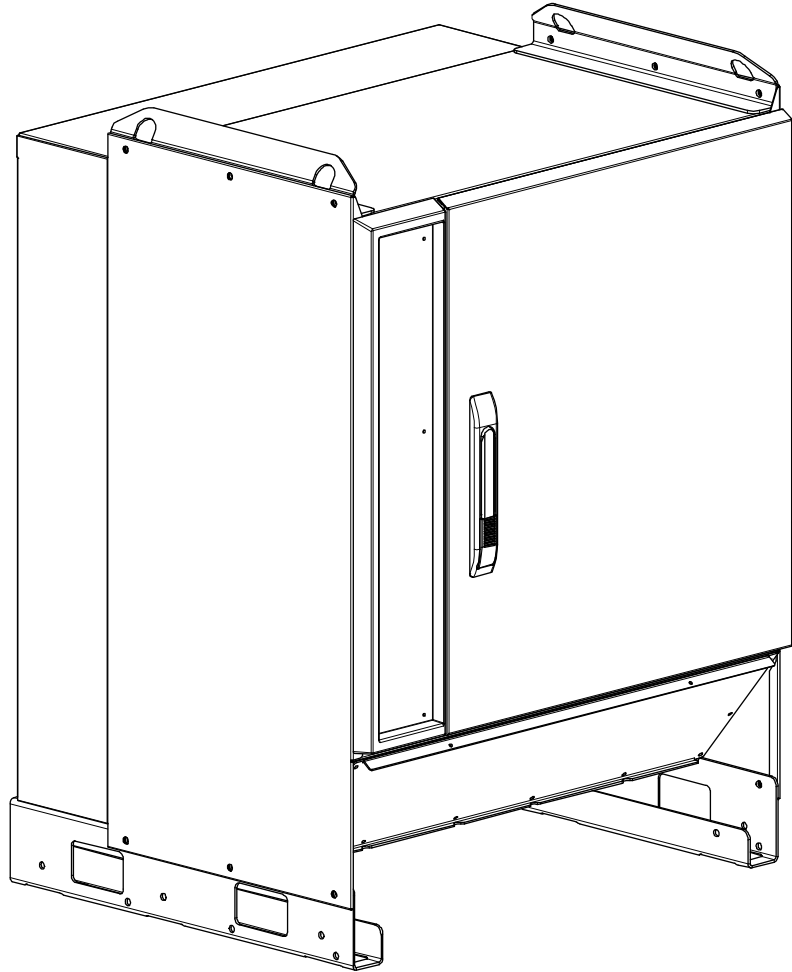

xx0900000976

Based on the single cabinet, this option is intended for customer equipment or extended use of I/O units.

Mounting plate dimensions (HxW): 711 x 660 mm.

Mounting depth (D): 250-325 mm

For cabinet dimensions see [Single cabinet controller on page 11](#).

1.1.8 MultiMove

General

It is possible to connect up to three additional Drive modules, each running one robot or a number of additional motors, to one Single cabinet controller or Control module. Each robot can control additional motors, see [Additional motors on page 41](#).



Note

Note that when several robots are connected to one Single cabinet controller or Control module, the complete cell is regarded as one robot from the safety system point of view.

A risk assessment, as outlined in ISO 10218-2, shall always be performed on the robot cell.

Module connections

The Drive modules are connected to the Single cabinet controller or Control module by an Ethernet cable and a safety signal cable with a maximum length of 75 m.



Note

Note that it is not necessary to have several Drive modules in order to run MultiMove, as long as the mechanical units are all connected to the same Drive module. One example is “manual jog”, where one additional axis is controlled from a separate task.

MultiMove system

With a MultiMove system, it is possible to operate the robots either individually (option 604-2 MultiMove Independent) or in a co-operative manner, (option 604-1 MultiMove Coordinated). Examples of the latter are:

- Dual robots welding on work objects rotated by an positioner
- Multiple robots together lifting a heavy object
- One robot holding a work piece while another robot is processing the work piece (typically welding)

Robot combinations

Arbitrary robots can be combined in a MultiMove system. However, for delta robots (for example, IRB 360) the following limitations apply:

- Maximum two delta robots can be connected in a MultiMove system. No more robots can be connected.
- A delta robot cannot be coordinated with another robot (delta or other robot).

For further information, see *Application manual - MultiMove*.

Continues on next page

1 Description of the IRC5 controller

1.1.8 MultiMove

Continued

Limitations

Note that screw terminals for signals from the additional robots (for example, customer signals) may not be possible to fit in the main robot cabinet. Especially the limited space in the Single cabinet requires attention. An empty cabinet (option 768-1 or option 768-2) is recommended to make room also for I/O units or customer PLC.

When combining MultiMove with track motion, it is only possible to use track motion on the first two robots. To use track motion on robot 3/4, a customization is required. Contact your local ABB organization.

Adding MultiMove option to existing robot

To run MultiMove, some additional components are included when ordering MultiMove from factory. However, if a MultiMove option is added to an existing robot, the following articles must be ordered too: 3HAC045976-001, 3HAC047352-001, 3HAC049813-001, 3HAC024254-005, 3HAB7983-1.

1.1.9 Additional motors

General

The IRC5 controller cabinet can be supplied with drive units for up to three additional motors. These motors are programmed and moved in the same way as the robot's motors. See figure below.

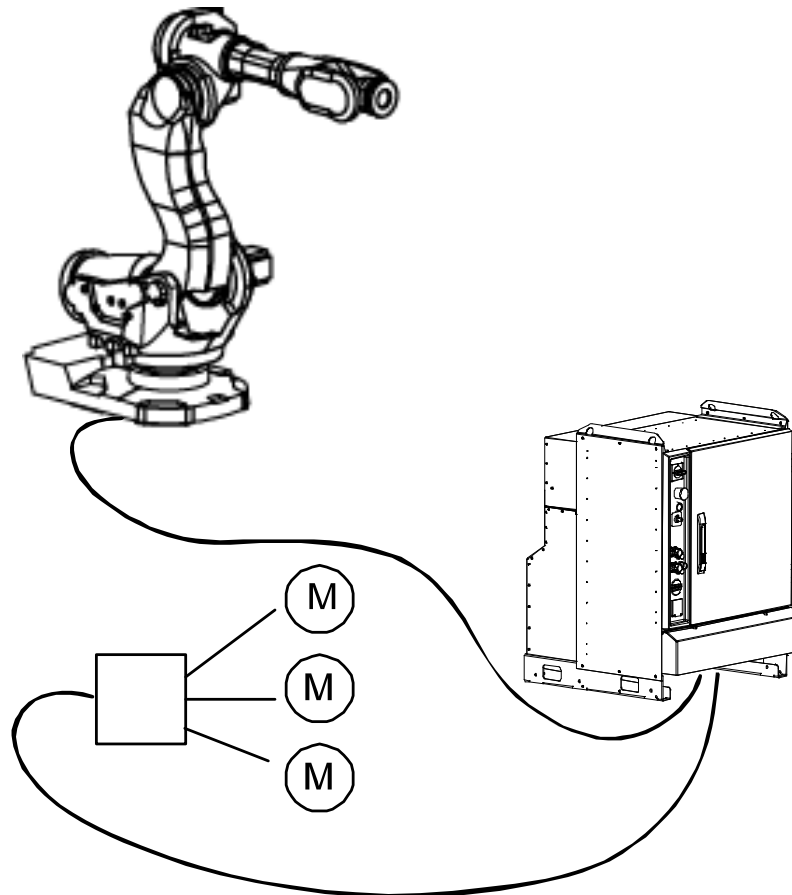

xx090000948



Note

Data for the individual drive units is found in chapter Drive unit data in *Application manual - Additional axes and stand alone controller*.

Additional Drive module connection

An IRC5 Drive module can be connected to the Single cabinet, independent of the robot type. An Ethernet switch plus cabling is the only additional hardware required. A Drive module is basically equipped with drives for 6 motors but can be supplied with drives for further 3 motors. The Drive module is complete with power distribution, transformer, dual MOTORS ON contactor circuits, cooling, power supply and axis computer.

Available drive system sizes corresponds to IRB 1600, IRB 2600 and IRB 66XX.

Continues on next page

1 Description of the IRC5 controller

1.1.9 Additional motors

Continued

See chapter Drive unit data in *Application manual - Additional axes and stand alone controller* for the individual drive units. Ordering additional Drive module is done via the Specification form "IRC5 Controller". Select the option 700-1 Drive module only and then option 751-x Drive system.

With maximum three additional Drive modules it is possible to control up to 36 motors.



Note

Note that an additional Drive module for additional motors reduces the maximum number of additional robots to two. See [MultiMove on page 39](#) (optional).

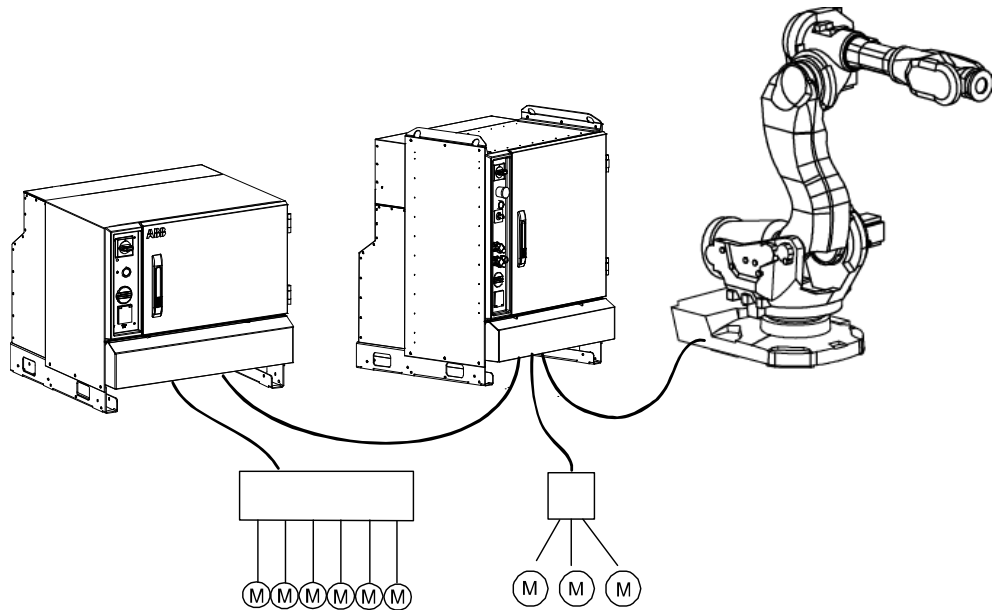

xx0900000949

Simultaneous coordination

Up to 12 motors, including the robot, can be active at the same time in the same motion task. The robot motion can be simultaneously coordinated with for example, a linear robot carrier and a work piece positioner.

Mechanical units

The additional motors can be grouped into mechanical units to facilitate, for example, the handling of robot carriers, workpiece manipulators, etc. All motors within a mechanical unit must be connected to the same Drive module.

Activation/Deactivation of mechanical unit

A mechanical unit can be activated or deactivated to make it safe when, for example, manually loading a workpiece on the unit. In order to reduce investment costs, any motors that do not have to be active at the same time, can share the same drive unit.

Continues on next page

Motor selection

For motor selection, see *Product specification - Motor Units and Gear Units*.



Note

ABB can not guarantee complete functionality when using third party equipment. Use of ABB verified equipment for optimal performance is recommended.

Absolute position

Absolute position is accomplished by battery-backed resolver revolution counters in the serial measurement board (SMB). Encapsulated SMB units are also described in *Product specification - Motor Units and Gear Units*.



Note

For more information on how to install an additional motor, see *Application manual - Additional axes and standalone controller*. This manual also specifies necessary resolver data, and how to create a simple dimensioning of the motor.

1 Description of the IRC5 controller

1.1.10 External panel

1.1.10 External panel

General

Both the operator's panel and the FlexPendant can be mounted externally, that is separated from the cabinet and the robot can then be controlled from there.

The optional remote panel contains:

- Emergency stop
- MOTORS ON
- Operating mode selector
- FlexPendant connector, inclusive optional Hot plug

Remaining on the Control cabinet:

- Mains switch
- Optional safety LEDs
- Service PC connection

The robot can also be controlled remotely from a computer, PLC or from a customer's panel, using serial communication (optional) or digital system signals.



Note

For more information on how to operate the robot, see *Operating manual - IRC5 with FlexPendant*, or *Operating manual - RobotStudio*.

1.2 Safety

1.2.1 Applicable standards



Note

The listed standards are valid at the time of the release of this document. Phased out or replaced standards are removed from the list when needed.

General

The product is designed in accordance with ISO 10218-1:2011, Robots for industrial environments - Safety requirements -Part 1 Robots, and applicable parts in the normative references, as referred to from ISO 10218-1:2011. In case of deviations from ISO 10218-1:2011, these are listed in the declaration of incorporation which is part of the product delivery.

Normative standards as referred to from ISO 10218-1

Standard	Description
ISO 9283:1998	Manipulating industrial robots - Performance criteria and related test methods
ISO 10218-2	Robots and robotic devices - Safety requirements for industrial robots - Part 2: Robot systems and integration
ISO 12100	Safety of machinery - General principles for design - Risk assessment and risk reduction
ISO 13849-1:2006	Safety of machinery - Safety related parts of control systems - Part 1: General principles for design
ISO 13850	Safety of machinery - Emergency stop - Principles for design
IEC 60204-1	Safety of machinery - Electrical equipment of machines - Part 1: General requirements

Region specific standards and regulations

Standard	Description
ANSI/RIA R15.06	Safety requirements for industrial robots and robot systems
ANSI/UL 1740	Safety standard for robots and robotic equipment
CAN/CSA Z 434-03	Industrial robots and robot Systems - General safety requirements

Other standards used in design

Standard	Description
ISO 9787:2013	Robots and robotic devices -- Coordinate systems and motion nomenclatures
IEC 61000-6-2	Electromagnetic compatibility (EMC) – Part 6-2: Generic standards – Immunity standard for industrial environments
IEC 61000-6-4	Electromagnetic compatibility (EMC) – Part 6-4: Generic standards – Emission standard for industrial environments

Continues on next page

1 Description of the IRC5 controller

1.2.1 Applicable standards

Continued

Standard	Description
ISO 13732-1:2006	Ergonomics of the thermal environment - Part 1
IEC 60974-1:2012 ⁱ	Arc welding equipment - Part 1: Welding power sources
IEC 60974-10:2014 ⁱ	Arc welding equipment - Part 10: EMC requirements
ISO 14644-1:2015 ⁱⁱ	Classification of air cleanliness
IEC 60529:1989 + A2:2013	Degrees of protection provided by enclosures (IP code)

ⁱ Only valid for arc welding robots. Replaces IEC 61000-6-4 for arc welding robots.

ⁱⁱ Only robots with protection Clean Room.

1.2.2 Safety functions

Safety

The robot controller is designed with absolute safety in mind. It has a dedicated safety system based on a two-channel circuit which is monitored continuously. If any component fails, the electrical power supplied to the motors is cut off and the brakes engage.

Safety functions	Description
Safety Performance Level d and category 3	Malfunction of a single component, such as a sticking relay, will be detected at the next MOTOR OFF/MOTOR ON operation. MOTOR ON is then prevented and the faulty section is indicated. The executing circuits are continuously monitored. This complies with Performance Level d and category 3 of EN ISO 13849-1, Safety of machinery - safety related parts of control systems - Part 1.
Selecting the operating mode	The robot can be operated either manually or automatically. In manual mode, the robot can only be operated via the FlexPendant or RobotStudio online, that is not by any other external equipment.
Reduced speed	In manual mode, the speed is limited to a maximum of 250 mm/s (600 inch/min.) and monitored by two independent computers. The speed limitation applies not only to the TCP (Tool Center Point), but also to the center of the mounting plate and the back of the upper arm. It is also possible to monitor the speed of equipment mounted on the robot.
Three position enabling device	The enabling device on the FlexPendant must be used to move the robot when in manual mode. The enabling device consists of a switch with three positions, meaning that all robot movements stop when either the enabling device is pushed fully in, or when it is released completely. This makes the robot safer to operate.
Safe manual movement	The robot is moved using a joystick instead of the operator having to look at the FlexPendant to find the right key.
Emergency stop	There is one emergency stop push button on the controller and another one on the FlexPendant. Additional emergency stop buttons can be connected to the robot's safety chain circuit.
Protective stop	The controller has a number of electrical inputs which can be used to connect external safety equipment, such as safety gates and light curtains. This allows the robot's safety functions to be activated both by peripheral equipment and by the robot itself. The stop can be uncontrolled (category 0) or controlled (category 1).
Controlled protective stop	A controlled stop gives a smooth stop. The robot stops the same way as at a normal program stop with no deviation from the programmed path. After approximately 1 second the power supplied to the motors is cut off.
Collision detection	In case of an unexpected mechanical disturbance like a collision, electrode sticking, etc., the robot will stop and then slightly back off from its stop position.
Restricting the working space	Software: <ul style="list-style-type: none"> The movement of each axes can be restricted Hardware: <ul style="list-style-type: none"> Moveable mechanical stops

Continues on next page

1 Description of the IRC5 controller

1.2.2 Safety functions

Continued

Safety functions	Description
Hold-to-run control	“Hold-to-run” means that you must depress a button continuously in order to move the robot. When the button is released the robot will stop. The hold-to-run function makes program testing safer. At reduced speed it can be activated/deactivated by a system parameter.
Fire safety	The control system complies with the requirement of UL (Underwriters Laboratories) for fire safety.
Safety lamp	As an option, a safety lamp mounted on the manipulator can be connected. The lamp is activated when the controller is in the MOTORS ON state.
MultiMove	When several robots are connected to one control module, all these robots are regarded as one robot from the point of view of the safety system. For example, all robots will be in the same operating mode and they will all be affected by an emergency stop or protective stop. When in manual mode one robot, or other mechanical unit, at a time can be jogged, selected from the FlexPendant. If in coordinated mode, all coordinated robots can be jogged simultaneously as well.

Minimum operating cycles for safety parts

The minimum expected cycles for safety parts is listed below.

Safety part	Minimum cycles
Enable device	100000
Emergency stop (FlexPendant)	500000
Emergency stop (operator panel)	500000
Mode switch (CAM Switch)	100000
Contactors K42, K43, K44	10000000
Automatic fuse F1	50000
Automatic fuse F2	20000
Automatic fuse F5	20000
Automatic fuse F6	50000

1.2.3 Safety data

About this section

This chapter describes the necessary safety data required by standard EN ISO 13849-1:2015.

Prevailing directives and standards

For the use of industrial robots and how to protect personnel from being injured, special regulations must be fulfilled as described in the following directives and standards:

- Machinery Directive 2006/42/EC
- EN ISO 10218-1:2011
- EN ISO 13849-1:2008 (when explicitly called forth by EN ISO 10218-1:2011 as ISO 13849-1:2006)
- EN ISO 13849-1:2015

Performance level and category

EN ISO 13849-1, which is a B-standard, describes the general concept of performance level (PL) and category. Each machine or machinery is potentially dangerous and can cause personal injury. Based on severity of injury and probability of accident, when using the machine, a certain level of safety performance, so called required performance level (PLr) can be defined, where *level a* represents the lowest risk and *level e* the highest. According to this, the machine must be equipped with safety related parts, meeting the required performance level, to reduce the risk to accepted low level. As specified in EN ISO 10218-1, normally *PL d* is required for robots, but depending on the applications a higher requirement could be needed if a risk analysis will result in *PL e*.

To comply with a certain PLr, in this case *d*, the safety related parts of the robots and controllers must be structurally designed according to specific structure categories and using reliable components.

In EN ISO 13849-1 it is in detail specified what category and components data, which must be met, to fulfill *PL d*. These are:

- Category 3, which is normally fulfilled using double channels
- MTTF_D (Mean Time To dangerous Failure) – high
- DC (Diagnostic Coverage) – low or medium
- CCF (Common Cause Failures) – better than 65 scores according to Annex F

Performance level for ABB IRC5 controller

To verify that robots and controller comply with at least *PL d* a self assessment has been carried out and documented in a *Technical Report*. The essential conclusions are accounted for below.

The safety related parts of robot and controller are e.g. the following stop circuits:

- Enabling device
- Emergency stop on operator panel

Continues on next page

1 Description of the IRC5 controller

1.2.3 Safety data

Continued

- Emergency stop on FlexPendant
- Limiting robot motion
- Protective stops
- SafeMove
- EPS
- SafeMove2

For the overall design and structure, the category 3 has been verified and meeting the requirements of CCF.

Each of the stop circuits includes different components like enabling switch, panel board, contactor board, relays etc. For each of these the $MTTF_D$ and DC have been calculated according to EN ISO 13849-1 Annex C, D and E resulting in the values as specified in the following table.

See the SISTEMA/ABB FSDT libraries for details of the safety functions.

IRC5 Single and IRC5 Panel Mounted Controller

Safety function	Calculated $MTTF_D$ [years]	DC_{avg}
Emergency stop inputs (operator panel)	112	Medium
Automatic stop input	120	Medium
General stop input	120	Medium
Superior stop input	120	Medium
Limiting switch input (without customer connection)	176	Medium
Three-position enabling device inputs	91	Medium
Emergency stop status outputs	239	Medium
Emergency stop inputs (source external)	101	Medium
SafeMove (option) (without customer connections)	58	Medium
Electronic Position Switches (option) (without customer connections)	105	Medium
SafeMove2 functions (option)		
Protective stop	370	Low
Emergency stop	370	Low
Emergency stop safe fieldbus output	370	Low
Speed supervision	370	Low
Speed supervision safe fieldbus output	370	Low
Position supervision	370	Low
Position supervision safe fieldbus output	370	Low
External power control	88	Low

Continues on next page

IRC5C Compact

Safety function	Calculated MTTF _D [years]	DC _{avg}
Emergency stop inputs (operator panel)	57	Medium
Automatic stop input	59	Medium
General stop input	59	Medium
Superior stop input	59	Medium
Limiting switch input (without customer connection)	59	Medium
Three-position enabling device inputs	51	Medium
Emergency stop status outputs	71	Medium
Emergency stop inputs (source external)	54	Medium
SafeMove2 functions (option)		
Protective stop	370	Low
Emergency stop	370	Low
Emergency stop safe fieldbus output	160	Low
Speed supervision	370	Low
Speed supervision safe fieldbus output	370	Low
Position supervision	370	Low
Position supervision safe fieldbus output	370	Low

Based on the values from the previous table of MTTF_D values, the corresponding PFH_D can be calculated using the Annex K, table K1 of EN ISO 13849-1:2008. These are shown in the following table.

IRC5 Single and IRC5 Panel Mounted Controller

Stop circuit	Calculated PFH _D	PL
Emergency stop inputs (operator panel)	4.29x10E-08	e
Automatic stop input	4.29x10E-08	e
General stop input	4.29x10E-08	e
Superior stop input	4.29x10E-08	e
Limiting switch input (without customer connection)	4.29x10E-08	e
Three-position enabling device inputs	4.94x10E-08	e
Emergency stop status outputs	4.29x10E-08	e
Emergency stop inputs (source external)	4.29x10E-08	e
SafeMove (option) (without customer connections)	1.03x10E-07	d
Electronic Position Switches (option)	4.29x10E-08	e
SafeMove2 functions (option)		
Protective stop	1.01x10E-07	d

Continues on next page

1 Description of the IRC5 controller

1.2.3 Safety data

Continued

Stop circuit	Calculated PFH _D	PL
Emergency stop	1.01x10E-07	d
Emergency stop safe fieldbus output	1.01x10E-07	d
Speed supervision	1.01x10E-07	d
Speed supervision safe fieldbus output	1.01x10E-07	d
Position supervision	1.01x10E-07	d
Position supervision safe fieldbus output	1.01x10E-07	d
External power control	1.35x10E-07	d

IRC5C Compact

Stop circuit	Calculated PFH _D	PL
Emergency stop inputs (operator panel)	1.03x10E-07	d
Automatic stop input	1.03x10E-07	d
General stop input	1.03x10E-07	d
Superior stop input	1.03x10E-07	d
Limiting switch input (without customer connection)	1.03x10E-07	d
Three-position enabling device inputs	1.19x10E-07	d
Emergency stop status outputs	7.68x10E-08	e
Emergency stop inputs (source external)	1.19x10E-07	d
SafeMove2 functions (option)		
Protective stop	1.01x10E-07	d
Emergency stop	1.01x10E-07	d
Emergency stop safe fieldbus output	1.01x10E-07	d
Speed supervision	1.01x10E-07	d
Speed supervision safe fieldbus output	1.01x10E-07	d
Position supervision	1.01x10E-07	d
Position supervision safe fieldbus output	1.01x10E-07	d

Conclusion according to EN ISO 13849-1:2015

The IRC5 controller safety system has a safety *category 3* with performance level *PL d* according to EN ISO 13849-1 using the simplified method of chapter 4.5.4 of EN ISO 13849-1 and thus fulfils the safety performance requirement of the robot safety standard EN ISO 10218-1.

The *Common Cause Failure* (CCF) is met according to the standard requirements.

1.3 Installation and maintenance

1.3.1 Installation

General

The controller is delivered with a standard configuration for the corresponding manipulator, and can be operated immediately after installation. Its configuration is displayed in plain language and can easily be changed using the RobotStudio or the FlexPendant.

Operating requirements

Requirements	Description
Dust and water protection according to IEC 529	Controller electronics IP54, air cooling ducts IP33 Variant Panel Mounted IP20
Cabinet protection	NEMA class 13
Explosive environments	The controller must not be located or operated in an explosive environment according to ATEX 94/9/EC.
Ambient temperature during operation	+0 °C (+32 °F) to +45 °C (+113 °F) (with option 708-2: +52 °C (+125 °F))
Ambient temperature during transportation and storage	-25 °C (-13 °F) to +55 °C (+131 °F) for short periods (not exceeding 24 hours): up to +70 °C (+158 °F).
Vibration during transportation	Max. ca. 0.9 g = ca. 10m/s ²
Vibration during operation	Max. ca. 0.15g = ca. 1.5m/s ²
Bumps during transportation and operation	Max. 5 g = 50 m/s ² (11 ms)



Note

The humidity conditions shall apply with the environmental conditions EN 60721-3-3, climatic class 3K3. For temperatures 0-30 °C, the relative humidity must not exceed 85%. For temperatures exceeding 30 °C, the absolute humidity must not exceed 25g/m³.

If the environmental conditions in EN 60721-3-3, climatic class 3K3, are not possible to meet at the installation site, desiccant bags can be placed inside the controller to achieve corresponding conditions. The desiccant bags must be replaced regularly to maintain approved operating conditions.

Power supply

Mains	Values
Voltage	200-600 V, 3 phase or 220/230 V, 1 phase
Voltage tolerance	+10%, -15%
Frequency	48.5 to 61.8 Hz

Continues on next page

1 Description of the IRC5 controller

1.3.1 Installation

Continued



Note

The use of three phase power with delta connection (as sometimes used in North Americas and some Asian countries) voids warranty. If the facility has a substation with any type of delta connection, a grounded Y-configured transformer must be installed before the robot controller.

Rated voltage and current

To find the rated voltage, the full load current, and short circuit current rating of the controller, see the name plate (label) on the side of the cabinet.

The illustration shows an example of the position of the label.

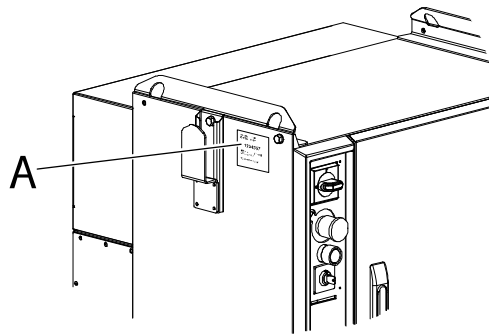

xx0900000273

A	Controller name plate
Short Circuit Current Rating (SCCR)	
	Ampere
UL/CSA	10 kA
EU(IEC)	6.5 kA



Note

The use of three phase power with delta connection (as sometimes used in North Americas and some Asian countries) voids warranty. If the facility has a substation with any type of delta connection, a grounded Y-configured transformer must be installed before the robot controller.

Line fusing

Recommended line fusing, slow-blowing diazed or circuit breaker with trip characteristic K. Max. fuse 35 A, with options 80 A.

Robot	Voltage	Recommended line fusing
IRB 1200, 260, 360, 1600	at 220/230 V	1x16 A (IRC5 Compact)
IRB 1200, 1600, 2400, 2600, 260, 360, 390, 4400	at 400-660 V	3x16 A
IRB 1200, 1600, 2400, 2600, 260, 360, 390, 4400	at 200-220 V	3x16 A
IRB 4600, 660, 460, 760, 66XX, 6700, 7600, 8700	at 400-600 V	3x25 A
IRB 660, 66XX, 6700, 760, 7600, 8700	at 200-220 V	3x35 A

Continues on next page

Robot	Voltage	Recommended line fusing
IRB 4600, 660, 460, 760, 66XX, 6700, 7600, 8700	at 200-220 V	3x35 A



Note

The label on the robot controller shows the rated voltage, the full load current, and the rated short-circuit current, intended for the electrical installation of the product. The actual power consumption in an application might be lower as it depends on the actual application.

Power consumption

See product specification for respective IRB.

When a connected manipulator is in MOTORS OFF mode or MOTORS ON with the brakes engaged (stand still), the typical IRC5 power consumption is 200/250W, customer I/O load excluded.

UPS

Computer system backup capacity (UPS)	Value
At power interrupt	20 sec (maintenance free energy bank)

Configuration

The controller is very flexible and can, by using RobotStudio or the FlexPendant, easily be configured to suit the needs of each user:

Configuration	Description
Authorization	Password protection IRC5 includes an advanced user authorization system, UAS. It includes administration of users and access rights connected to user names and passwords. The same user can have different access rights for different parts of the robot system.
Most common I/O	User-defined lists of I/O signals.
Instruction pick list	User-defined set of instructions.
Instruction builder	User-defined instructions.
Operator dialogs	Customized operator dialogs.
Language	All text on the FlexPendant can be displayed in several languages.
Date and time	Calendar support.
Power on sequence	Action taken when the power is switched on.
EM stop sequence	Action taken at an emergency stop.
Main start sequence	Action taken when the program is starting from the beginning.
Program start sequence	Action taken at program start.
Program stop sequence	Action taken at program stop.
Change program sequence	Action taken when a new program is loaded.

Continues on next page

1 Description of the IRC5 controller

1.3.1 Installation

Continued

Configuration	Description
Working space	Working space limitations.
Additional axes	Number, type, common drive unit, mechanical units.
Brake delay time	Time before brakes are engaged.
I/O signals	Logical names of boards and signals, I/O mapping, cross connections, polarity, scaling, default value at start up, interrupts, group I/O etc., see I/O system on page 65 .
Serial communication (optional)	Configuration

For a detailed description of the possible configurations, see *Technical reference manual - System parameters*.

The installation procedure is described in the product manual for the respective controller variant, see [References on page 7](#).

1.3.2 Maintenance

General

The controller requires only a minimum of maintenance during operation. It has been designed to make it as easy to service as possible.

See the product manual for the controller for maintenance activities and intervals.

The controller is enclosed, which means that the electronic circuitry is protected when operating in a workshop environment. The only maintenance parts are cooling fans and optional air filters.

Functions

The robot has several functions to provide efficient diagnostics and error reports.

Function	Detail
Online supervision	Internal hardware functions
	CPU temperature
	CPU power levels
	AC and DC voltage levels
	Power Supply functions
	UPS capacitor status
	All internal communication channels (cables)
	CMOS battery
	Safety chains (two channel supervision)
	Safety chains (function test)
	Safety switches
	Operating mode switch
	Motor temperatures
	Drive system: communication cable, voltage levels, temperatures, motor current and cable, reference quality
	Measurement system: communication cable, resolver function including cables
Fieldbus cable (communication and power)	
Fieldbus units (connection, status)	
Program execution and resource handling	
Power on	Built-in self-test
Fault tracing support	Computer status LEDs and console (serial channel) optional
Error message	Displayed in selected language The message includes the reason for the fault and suggests recovery action
Faults and major events are logged and time-stamped.	This makes it possible to detect error chains and provides the background for any downtime. The log can be saved to file or viewed from PC tools like RobotStudio, Robot Web Services or any OPC client application

Continues on next page

1 Description of the IRC5 controller

1.3.2 Maintenance

Continued

Function	Detail
Manual test	Commands and service programs in RAPID to test units and functions
Properties	Detailed properties of hardware and software in the controller are available for viewing from FlexPendant or RobotStudio
Safety chain status LEDs	On the panel unit (std) On the operator's panel (optionally)

User program

Most errors detected by the user program can also be reported to and handled by the standard error system. Error messages and recovery procedures are displayed in plain language.

1.4 Computer system

1.4.1 The IRC5 main computer

General

The IRC5 main computer is included in all types of controllers.

PCI options

Two slots are available for hardware extension.

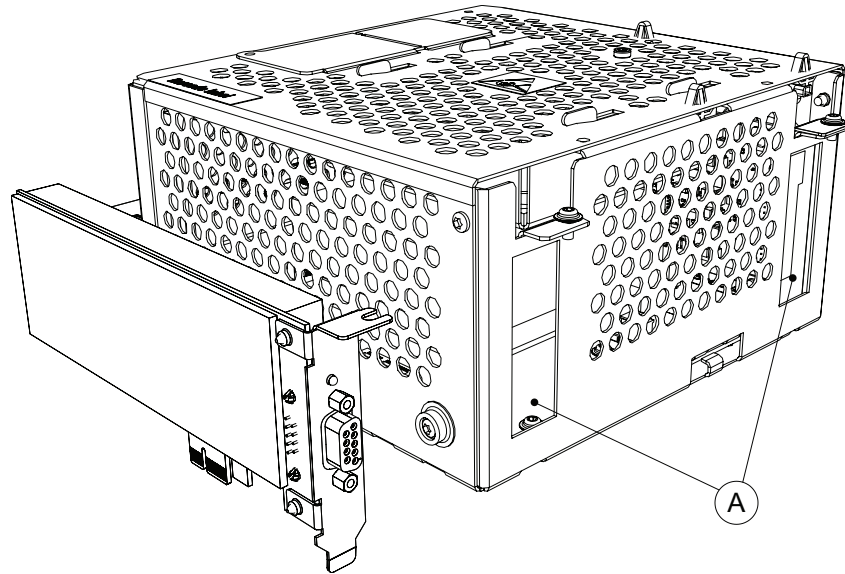

xx130000603

Pos	Description
A	Slot for PCIe cards

Continues on next page

1 Description of the IRC5 controller

1.4.1 The IRC5 main computer

Continued

Ethernet connections

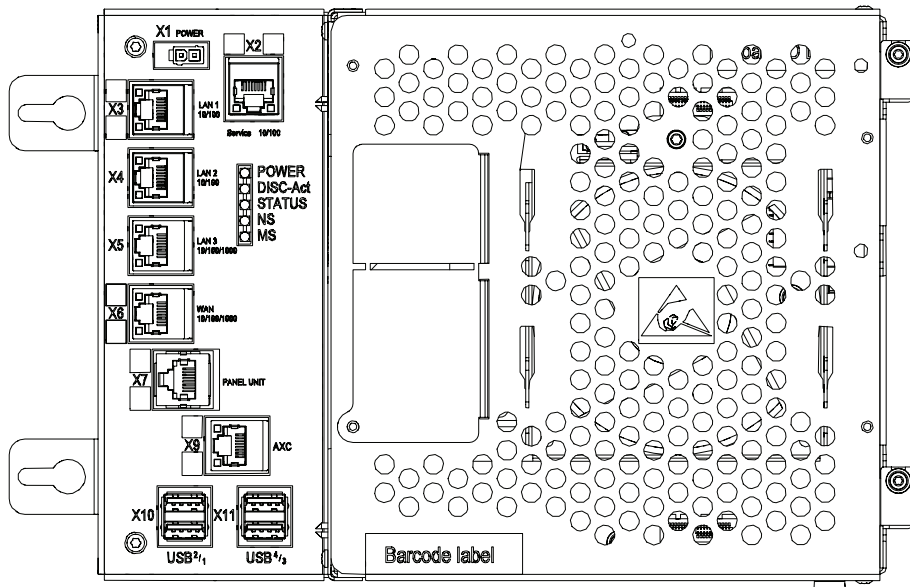

X1	Power supply
X2 (yellow)	Service (connection of PC)
X3 (green)	LAN1 (connection of FlexPendant)
X4	LAN2 (connection of Ethernet based options, 888-X, 841-1, 941-1)
X5	LAN3 Connection of Ethernet based options, 888-X, 849-1, 941-1)
X6	WAN (connection to factory WAN, options 707-1 or 906-1)
X7 (blue)	Panel unit
X9 (red)	Axis computer
X10, X11	USB ports (4 ports)

Priority for EtherNet ports vs. options

Prio	Option	LAN2	LAN3	WAN
1	941-1 EtherNet switch		X	
3	707-1 EtherNet RJ45 on front			X
4	906-1 EtherNet M12 on front			X
5	841-1 EtherNet/IP		X	X
6	888-X PROFINET SW		X	X

1.4.2 Communication

Ethernet

The controller has several Ethernet channels which can be used at 10 Mbit/s or 100Mbit/s. The communication speed is set automatically.

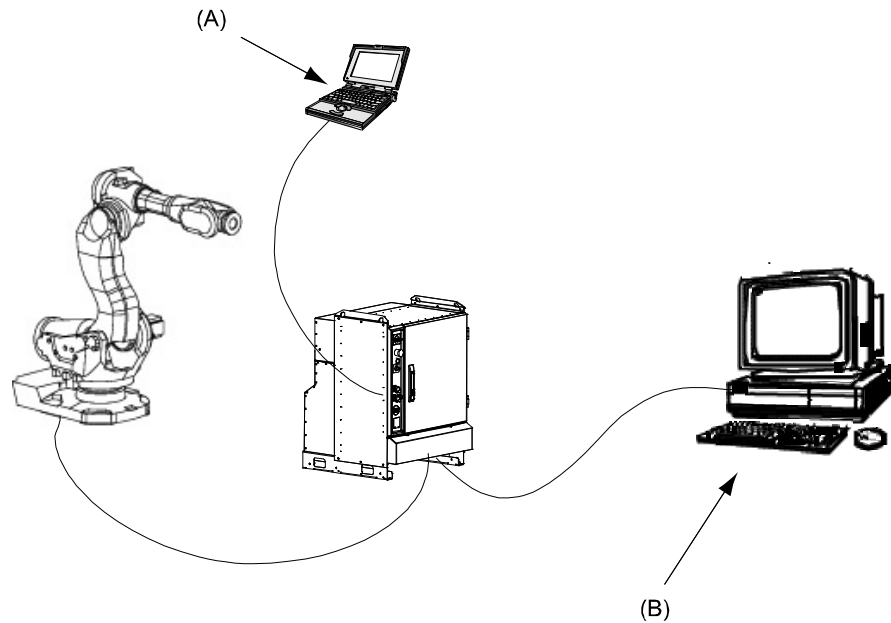

xx0900000957

Pos	Description
A	Temporary Ethernet for service, not for network
B	Permanent Ethernet

The communication includes TCP/IP with network configuration possibilities like:

- DNS, DHCP etc. (including multiple gateway)
- Network file system access using FTP/NFS client and FTP server
- Control and/or monitoring of controllers over OPC or by Windows applications built with PC SDK
- Boot/upgrading of controller software via the network or a portable PC
- Communication with RobotStudio

Continues on next page

1 Description of the IRC5 controller

1.4.2 Communication

Continued

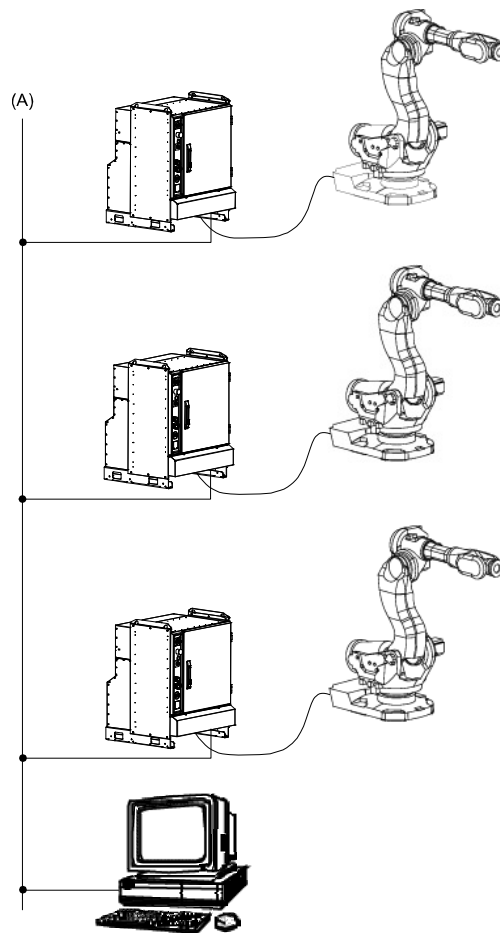

xx0900000958

Pos	Description
A	Factory network

Serial channel

The controller has one optional serial channel (option 970-1) RS232 for permanent use which can be used for communication point to point with printers, terminals, computers and other equipment.

The serial channel can be used at speeds up to 115.2 kbit/s.

The RS232 channel can be converted to RS422 or RS485 with an adapter. The following modes of operation are supported:

- RS422
- RS485 4-wire (full duplex, Master)



Note

Synchronous (clocked) mode is NOT supported.

1.4.3 Memory

Available memory

Filesystem FAT32 is supported.

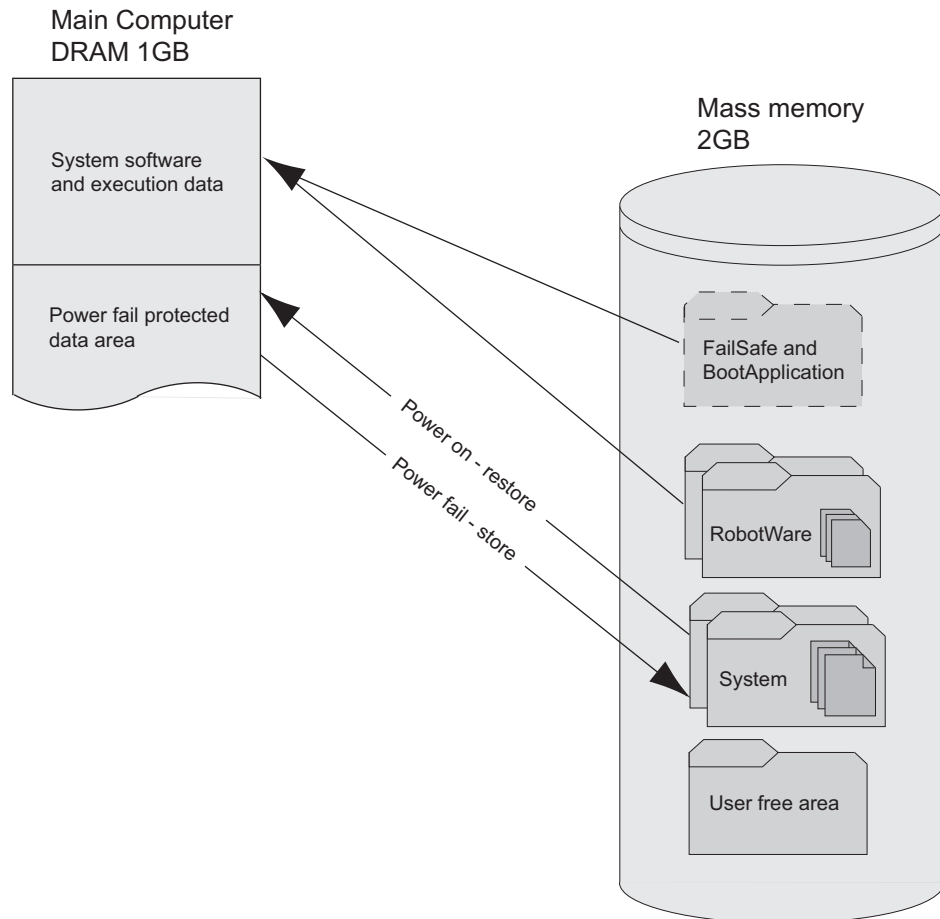

en1300001611

DRAM memory

The DRAM memory is used for runtime storage of the operating system and RobotWare. It also contains the power fail protected data used for RAPID memory, configuration, event logs, etc.

The size and the free space of the DRAM memory can be seen in the window *System Info* on the FlexPendant.

Mass memory

The mass memory is used for permanent storage of operating system, RobotWare, systems and user data.

The total size and the free space of the mass memory can be seen in the window *System Info* on the FlexPendant.

Continues on next page

1 Description of the IRC5 controller

1.4.3 Memory

Continued

RAPID memory

The RAPID memory consists of an internal representation of the RAPID programs and data. The memory also contains runtime stacks and data that are needed for the RAPID interpreter.

The RAPID memory is power fail protected and therefore the programs and data do not need to be reloaded after system powered off/on.

The total available memory for user programs can vary depending on the number of installed RobotWare options. The total size of the RAPID memory is statically allocated and will not vary during runtime.

The total size and the free space of the RAPID memory can be seen in the window *System Info* the FlexPendant.

The storage allocated for the programs depends on the type of data and instructions that are used and not on the size of the program files on disk, see [Example of RAPID memory consumption on page 64](#).



Note

RAPID tasks in a Multitasking and MultiMove system share the same memory.

Example of RAPID memory consumption

For details on RAPID memory consumption, see *Technical reference manual - RAPID kernel*.

Introduction	Robtarget marked (*)	Robtarget named
MoveL or MoveJ	312 bytes	552 bytes

1.4.4 I/O system

Fieldbus master/slave

There is a choice of different fieldbus types (option):

Option	Description	Number of I/O units
DeviceNet™	PCIe card certified by ABB included	20
PROFIBUS DP Master	PCIe card certified by ABB included	20
PROFINET IO SW	Software based	50
EtherNet/IP™	Software based	50 units (4049 signals/unit)

This makes it possible to mount the I/O units either inside the cabinet or outside the cabinet with a bus cable connecting the I/O unit to the cabinet.

Multiple fieldbuses can be installed in parallel with both master and slave functionality. Maximum total number of I/O units is 50.

For all bus types commercially available third party I/O units can be used.

For DeviceNet™, a number of different I/O units are available from ABB, see [ABB DeviceNet™ I/O units \(node types\) on page 70](#), and [Internal DeviceNet I/O on page 129](#).

Fieldbus adapter (slave)

The adapter is docked directly into the main computer. The adapter consists of a slave unit which enables communication with a master, either of:

- EthernetNet/IP™
- PROFIBUS DP
- PROFINET IO
- DEVICNET

Fieldbus gateway (slave)

A gateway unit acts as a translator between IRC5 DeviceNet™ and the customer fieldbus master:

- CC-Link

Number of logical signals

The maximum number of logical signals is 12000 in total for all installed fieldbuses (inputs or outputs, group I/O, analog and digital).

Continues on next page

1 Description of the IRC5 controller

1.4.4 I/O system

Continued

System signals

Signals can be assigned to special system functions such as program start, so as to be able to control the robot from an additional panel or PLC. Several signals can be given the same functionality.



Note

For more information on system signals, see *Technical reference manual - System parameters*.

Digital inputs

- Backup
- Collision Avoidance
- Disable backup
- Enable Energy Saving
- Interrupt
- Limit Speed
- Load
- Load and Start
- Motors Off
- Motors On
- Motors On and Start
- PP to Main
- Reset Emergency Stop
- Reset Execution Error Signal
- Set Speed Override
- SimMode
- Soft Stop
- Start
- Start at Main
- Stop
- Stop at End of Cycle
- Stop at End of Instruction
- System Restart
- Quick Stop
- Write Access

Digital outputs

- Absolute Accuracy Active
- Auto On
- Backup Error
- Backup in Progress
- Collision Avoidance

Continues on next page

- CPU Fan Not Running
- Cycle On
- Emergency Stop
- Energy Saving Blocked
- Execution Error
- Limit Speed
- Mechanical Unit Active
- Mechanical Unit Not Moving
- Motion Supervision On
- Motion Supervision Triggered
- Motors Off
- Motors Off State
- Motors On
- Motors On State
- Path Return Region Error
- Power Fail Error
- PPMoved
- Production Execution Error
- Robot In Trusted Position
- Robot Not On Path
- Run Chain OK
- SimMode
- Simulated I/O
- SMB Battery Charge Low
- Speed Override
- System Input Busy
- TaskExecuting
- Temperature Warning
- Write Access

Analog outputs

- TCP Speed
- TCP Speed Reference

General I/O

The inputs and outputs can be configured to suit your installation:

- Each signal and unit can be given a name, for example gripper, feeder
- I/O mapping (that is a physical connection for each signal)
- Polarity (active high or low)
- Cross connections
- Up to 32 digital signals can be grouped together and used as a single signal when, for example, entering a bar code

Continues on next page

1 Description of the IRC5 controller

1.4.4 I/O system

Continued

- Sophisticated error handling
- Selectable "trust level" (that is what action to take when a unit is "lost")
- Program controlled enabling/disabling of I/O units
- Scaling of analog signals
- Filtering
- Pulsing
- TCP-proportional analog signal
- Programmable delays
- Virtual I/O (for forming cross connections or logical conditions without need for the physical hardware)
- Accurate coordination with motion

PLC

The robot can function as a PLC by monitoring and controlling I/O signals:

- I/O instructions are executed concurrent to the robot motion.
- Inputs can be connected to trap routines. When such an input is set, the trap routine starts executing. Following this, normal program execution resumes. In most cases, this will not have any visible effect on the robot motion, as long as a reasonable number of instructions are executed in the trap routine.
- Background programs (for monitoring signals, for example) can be run in parallel with the actual robot program. This requires the option Multitasking, see *Product specification - Controller software IRC5*.

Manual functions

Manual functions are available to:

- List all the signal values
- Create your own list of your most important signals
- Manually change the status of an output signal

Scalable I/O

Introduction

Scalable I/O is a modular, compact, and scalable I/O system that consists of a base unit, which is the minimum configuration, and add-on units. Up to four add-on units can be controlled by a base unit with maintained performance, and any combination of add-on units are supported.

The I/O devices communicates over the EtherNet/IP communication protocol to the robot controller or to other EtherNet/IP scanners. When using the standard Plug & Produce interface no additional RobotWare options or hardware options are required to connect to the robot controller.

In this standard configuration the devices must be connected to the Ethernet port LAN 2 on the main computer.

When using the RobotWare option EtherNet/IP Scanner/Adapter more configuration possibilities are available, and the I/O devices can be connected to any of the Ethernet ports WAN, LAN 2, or LAN 3 on the main computer.

Continues on next page

The add-on devices have an optical interface and must be attached to the base device. The additional Ethernet port on the base device can be used to daisy chain any Ethernet based equipment on the same network, for example additional base devices.

The I/O devices are designed to be mounted vertically on a mounting rail in an IP20 protected environment with normal air convection. Forced air is needed if the devices are mounted horizontally.

The following I/O devices are available:

- Base module with industrial network connectivity, 16 digital inputs, and 16 digital outputs.
- Add-on module with 16 digital inputs and 16 digital outputs.
- Add-on module with 4 analog inputs and 4 analog outputs.
- Add-on module with 8 digital inputs and 8 relay outputs.

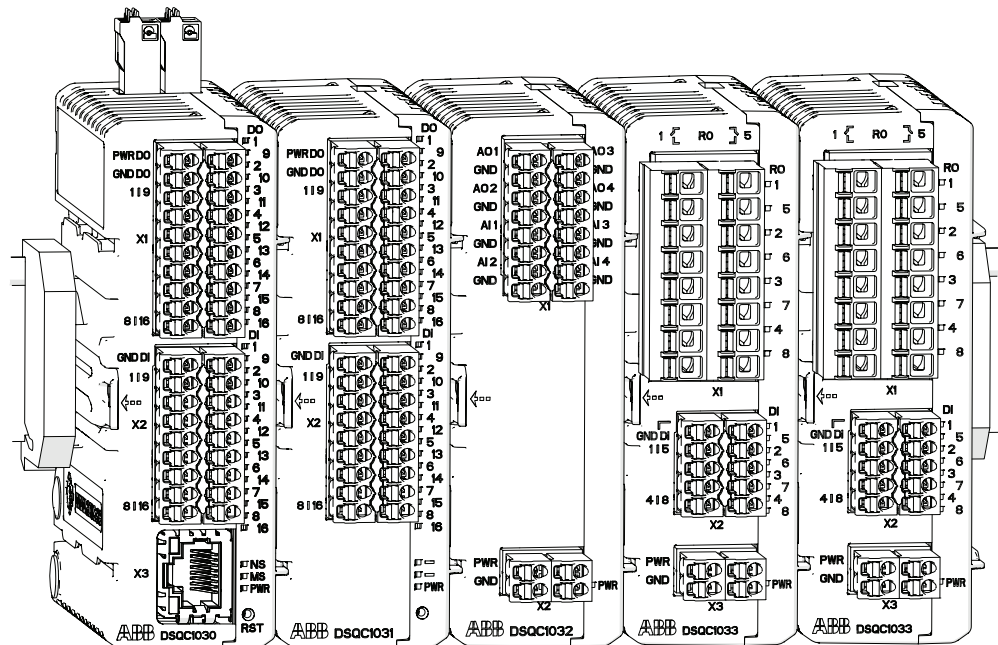

xx1600002032

See options [Scalable I/O on page 126](#).

Features

- Easy to install.
- Easy to configure in RobotWare with support of the new Plug & Produce interface.
- Compact and scalable.
- Can be mounted inside the controller and/or distributed outside.
- Supports standard DIN-rail mounting.
- Galvanically isolated add-on devices.
- Dual port switch for Daisy chaining.

Electrical data

Digital I/O Electrical data

Continues on next page

1 Description of the IRC5 controller

1.4.4 I/O system

Continued

Supply voltage 21 – 28 V DC Output current Nominal 500 mA per output, short circuit protected Input voltage levels - 30 – 5 V digital low , 15 – 30 V digital high Input current < 0.5 mA

Analog I/O Electrical data

Input voltage 0 - +10 V Output voltage 0 - +10 V Resolution 12 bit

Relay I/O Electrical data

Max voltage 230 V AC per contact Max current 2 A per contact

ABB DeviceNet™ I/O units (node types)

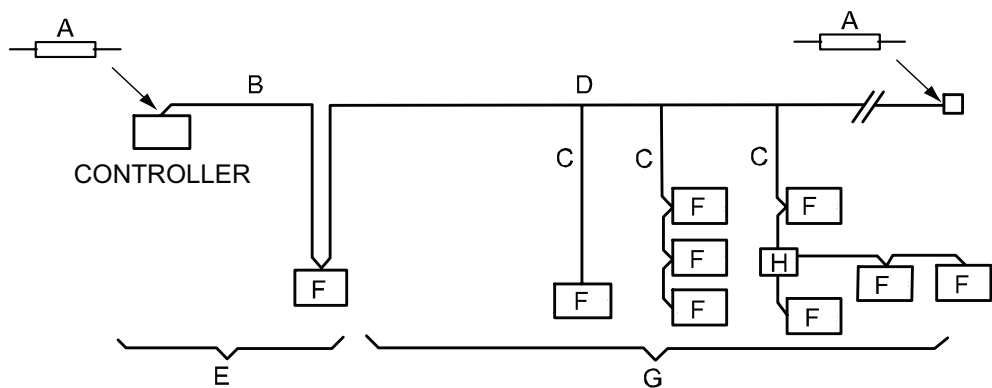

xx0300000579

Pos	Description	Remark
A	Terminator	
B	Trunk line	
C	Drop line	
D	Tap	
E	Zero drop	
F	I/O unit	
G	Short drop	
H	T-connector	

The table shows the maximum number of physical signals that can be handled by each unit.

Type of unit	DSQC	Option No.	In	Out	Voltage output	Power supply	Bus speed
Digital I/O 24 VDC	652	716-1	16	16		Internal/External	Auto detect
CC-Link gateway	378B	723-1	176	176			500 kB/s
Encoder interface unit	377B	726-1	1				500 kB/s

Maximum four ABB DeviceNet™ I/O or three gateway units can be mounted in the Single cabinet controller (inside of door).

Continues on next page

Power supply

In the Single Cabinet, there is always 24 V DC available at door terminals. The rated current depends on robot size and if additional motors are supplied from the cabinet.

Robot type	24 V I/O
IRB 1200 - 4400	8 A
IRB 1200 - 4400 with 3 X MU	8 A
IRB 4600 - 7600	8 A
IRB 4600 - 7600 with 3 x MU	5 A

The DSQC609 is possible to order with the Single Cabinet (max 2 units).

Type	Name	Data
Single Cabinet basic	24 V I/O	Output voltage 24 V DC - 2% + 10%. 0 V directly grounded to chassis. Rated continuous load see table above Output over current protection < 8 A, short circuit protected Output over voltage protection < 31.2 V Output hold-up > 20 ms Output noise/ripple < 200 mV p-p
Option 727-x, 886-1 DSQC609	Customer I/O Power supply	Input 230 V AC Output voltage 24 V DC - 1% + 10%. 0 V directly grounded to chassis. Rated continuous load 4 A Output over current protection < 4.16 A, short circuit protected Output over voltage protection < 31.2 V Output hold-up > 20 ms Output noise/ripple < 200 mV p-p
Option 728-1	DeviceNet™ Power supply	Input 230 V AC Output voltage 24 V DC - 1% + 5%, galvanically isolated from chassis. Rated continuous load 3.9 A Output over load protection < 100 VA Output over voltage protection < 36 V Output hold-up > 20 ms Output noise/ripple < 200 mV p-p Fulfills Limited Power Source NEC Class 2 requirement

The DeviceNet unit isolated outputs minimize the risk for ground loops due to potential differences that can occur if a distributed bus has several 0 V groundings.

Signal data

Digital inputs (options 716-1)	Values
24 V DC Optically isolated	
Rated voltage	24 V DC

Continues on next page

1 Description of the IRC5 controller

1.4.4 I/O system

Continued

Digital inputs (options 716-1)	Values
Logical voltage levels	"1" 15 to 35 V "0" - 35 to 5 V
Input current at rated input voltage	6 mA
Potential difference	max. 500 V
Time delays	hardware filter = 5 ms (\pm 0.5 ms) software delay \leq 0.5 ms ⁱ
Time variations	-1 ms +2 ms

ⁱ Software delay time is depending on connection type. The time presented here is for default settings, Change-Of-State with production inhibit time 10 ms.

Digital outputs (options 716-1)	Values
24 V DC Optically isolated	short-circuit protected, supply polarity protection
Voltage supply	19 to 35 V
Rated voltage	24 V DC
Logical voltage levels	"1" 18 to 34 V "0" < 7 V
Output current	max. 0.5 A/channel
Potential difference	max. 500 V
Time delays	hardware \leq 0.5 ms software \leq 1 ms
Time variations	-1ms + 2 ms

1.5 Operator's interface

1.5.1 FlexPendant

FlexPendant versions

The FlexPendant is available in different versions, as the hardware has been updated over the years. The exact appearance on the graphics might therefore differ slightly from reality.

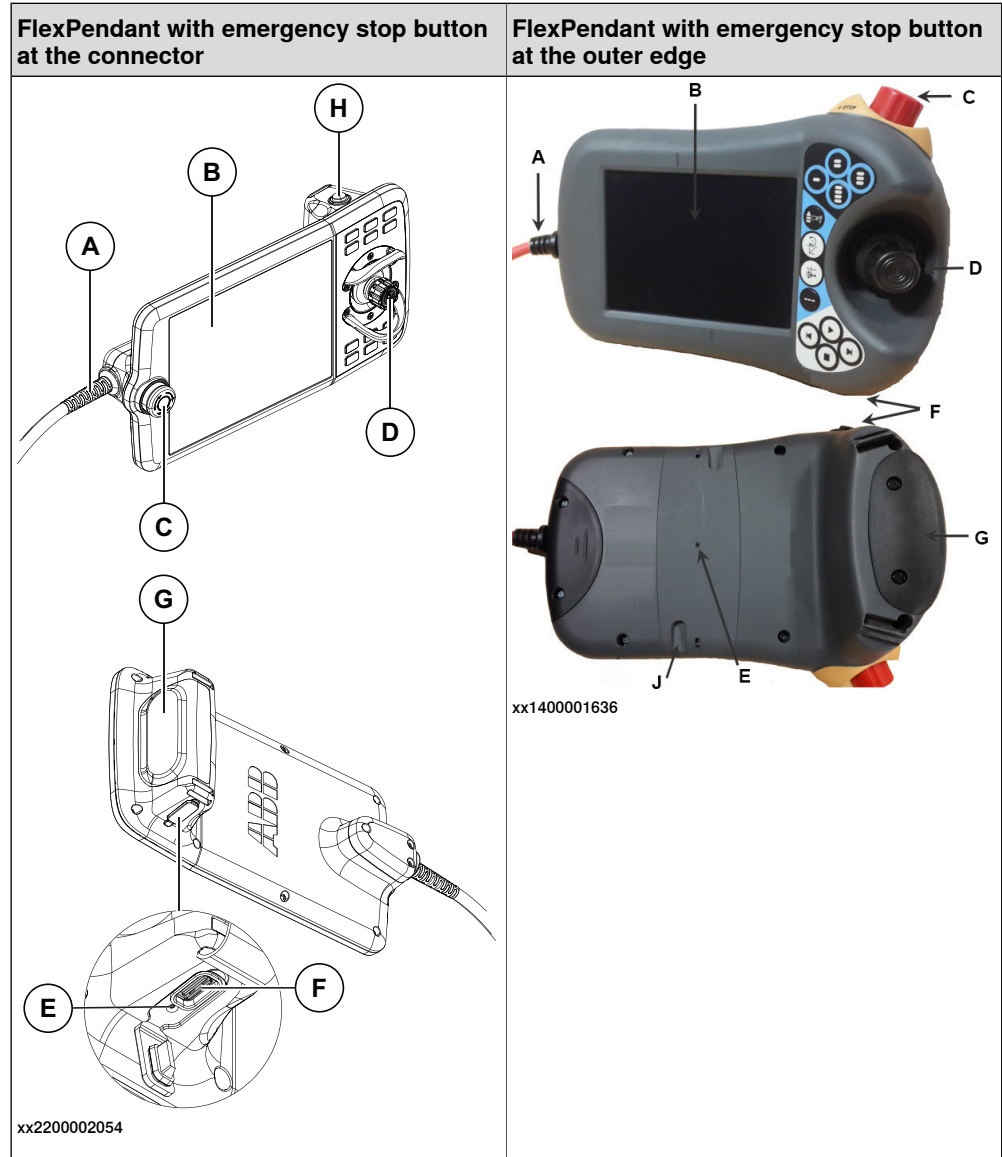

A	Connector
B	Touchscreen
C	Emergency stop button
D	Joystick
E	Reset button
F	USB port

Continues on next page

1 Description of the IRC5 controller

1.5.1 FlexPendant

Continued

G	Three-position enabling device
H	Thumb button (Not available on all versions of FlexPendant.)
J	Stylus pen (Not available on all versions of FlexPendant.)

Overview of functions

All operations and programming can be carried out using the FlexPendant. How to use the FlexPendant is described in *Operating manual - IRC5 with FlexPendant*.

The information is presented on the display in an intuitive way. No previous programming or computer experience is required to learn how to use the FlexPendant. All information is in English or, if preferred, another supported language. Two alternative languages, besides English, can be installed without reloading RobotWare. See [Available languages on page 74](#).

Features	Description
Display with touchscreen	A color touchscreen which displays text as well as graphical information. User input is entered by pressing menu commands, push buttons on the screen. Several windows can be open simultaneously. Zoom in and out is available in many views. Many properties of the display can be set by the user for a personalized look and feel. It is possible to invert the display and joystick directions to make the FlexPendant suitable for left handed users. The FlexPendant can house powerful user applications built on Microsoft.NET technology.
Program execution keys	Keys for program start/stop and stepwise execution forward/backward.
Hold-to-run	One of the hold-to-run buttons must be pressed continuously when running the program in manual mode with full speed.
Programmable keys	Four user-defined keys that can be configured to set or reset an output (for example open/close gripper) or to activate a system input.
Jogging keys	Four action keys for jogging.
Three-position enabling device	A push button which, in manual mode, when pressed halfway in, takes the system to MOTORS ON. When the three-position enabling device is released or pushed all the way in, the robot is brought to the MOTOR OFF state.
Joystick	The 3D joystick is used to jog (move) the robot manually; for example when programming the robot. The user determines the speed of this movement, large deflections of the joystick will move the robot quickly, smaller deflections will move it more slowly.
Emergency stop button	The robot stops immediately when the button is pressed in.

Available languages

The following languages are available on the FlexPendant:

- Chinese
- Czech
- Danish

Continues on next page

- Dutch
- English
- Finnish
- French
- German
- Hungarian
- Italian
- Japanese
- Korean
- Polish
- Portuguese
- Romanian
- Russian
- Slovenian
- Spanish
- Swedish
- Turkish

Example of FlexPendant window

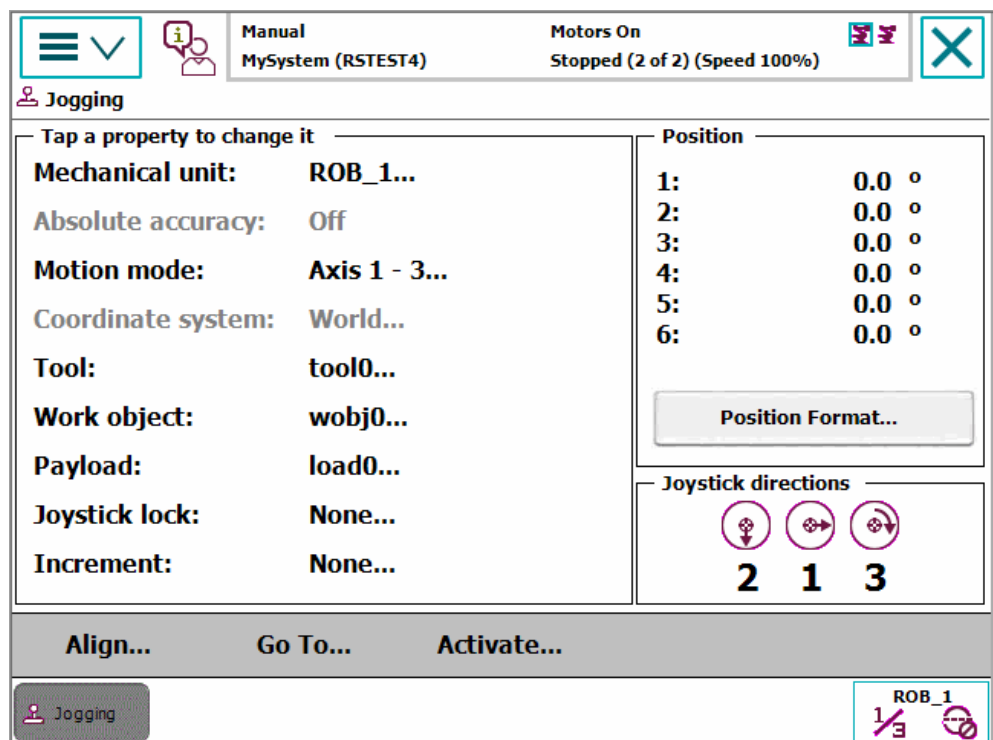

en040000654

1 Description of the IRC5 controller

1.5.2 RobotStudio

1.5.2 RobotStudio

Overview

RobotStudio is a PC application for working efficiently with IRC5 data. RobotStudio can be seen as a companion to the FlexPendant, where the two complement each other and each is optimized for its specific tasks. By exploiting the benefits of this powerful combination, a new efficient way of working can be achieved.

The FlexPendant is primarily intended for jogging, teach-in, operation and touch-up, whereas RobotStudio is ideal for dealing with configuration data, program management, on-line documentation and remote access.

RobotStudio acts directly on the active data in the controller. Connection to the controller can be made locally through the Service PC connection and, if the controller is equipped with the RobotWare option PC Interface, over a network connection.

A safe mastership handling system ensures that RobotStudio can only take control of a robot if this is acknowledged from the FlexPendant.

The main entry to the functionality of RobotStudio is a robot view explorer. From this you select which robot to work with, in case you have several robots installed, and what parts of the system you want to work with.

RobotStudio basic delivery contains:

- The Installation Manager for creating, installing and maintaining systems
- A Configuration Editor for editing the system parameters of the running system
- A Program Editor for online programming
- An Event Recorder for recording and monitoring robot events
- Tools for backing up and restoring systems
- An administration tool for User Authorization
- Other tools for viewing and handling controller and system properties

Access to the full scope of RobotStudio as a powerful off-line programming and simulating tool is ordered separately.

See *Operating manual - RobotStudio* for detailed information.

Configuration Editor

Use the Configuration Editor to make easy and controlled changes of system parameters on a running system.

From the configuration editor you view and edit the system parameters of a specific topic in a controller. The Configuration Editor has direct communication with the controller. This means that changes apply as soon as you complete the command.

For some parameters, however, a restart is required in order for the change to take effect, in which case you will be notified of this.

Continues on next page

Program Editor

With the Program Editor you view and edit programs loaded into the controller's program memory. The Program Editor has built in functionality for making it easier to write the RAPID code when programming a robot.

Event Recorder

With the Event Recorder you can view and save events from controllers in your robot view. You can start one Event Recorder for each controller.

Miscellaneous

RobotStudio has a number of other useful tools, for example:

- Backing up and restoring systems
- Administration tool for User Authorization
- And other tools for viewing and handling controller and system properties. for example monitoring of I/O signals

1 Description of the IRC5 controller

1.5.3 Connected Services

1.5.3 Connected Services

Connected Services box

The purpose of the Connected Services box is to act as a bridge between the robot controller and a remote server. The connection between the service box and the remote server is made by using a wireless GPRS or WiFi/4G technology and the Internet. Through the console port and the Ethernet port the information from the robot is buffered, parsed and filtered to obtain valuable service information in the Connected Services application.



Note

ABB Connect is the new name for previously known ABB Ability. During a period of time, both ABB Connect and ABB Ability will appear on our products.

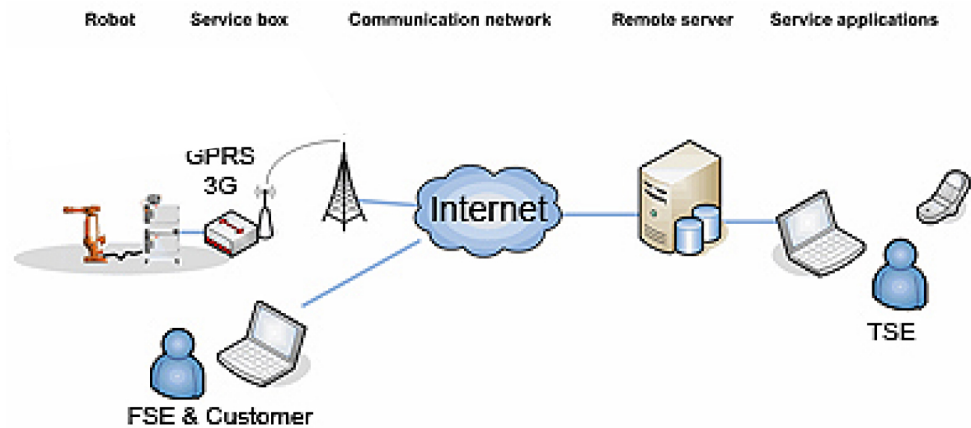

xx0900000947

1.6 Programming

1.6.1 Programming

General

Programming the robot can be done both from the FlexPendant or RobotStudio. On the FlexPendant, instructions and arguments are picked from lists of appropriate alternatives. In RobotStudio, programs are typed in a free text format and checked for errors when "Apply Changes" is clicked (if no errors, the changes immediately take effect in the robot memory).

Programming environment

The programming environment can be easily customized:

- Shop floor language can be used to name programs, signals, counters, etc
- New instructions with suitable names can be created
- The most common instructions can be collected in easy-to-use pick lists
- Positions, registers, tool data, or other data, can be created

Programs, parts of programs and any modifications can be tested immediately without having to translate (compile) the program.

Movements

A sequence of movements is programmed as a number of partial movements between the positions to which you want the robot to move.

End position

The end position of a movement is selected either by manually jogging the robot to the desired position with the joystick, by referring to a previously defined position or by defining numeric values.

Position types

A position can be defined either as:

- a stop point, that is the robot reaches the programmed position.
 - or a fly-by point, that is the robot passes close to the programmed position. The size of the deviation is defined independently for the TCP, the tool orientation and the additional axes.
-

Continues on next page

1 Description of the IRC5 controller

1.6.1 Programming

Continued

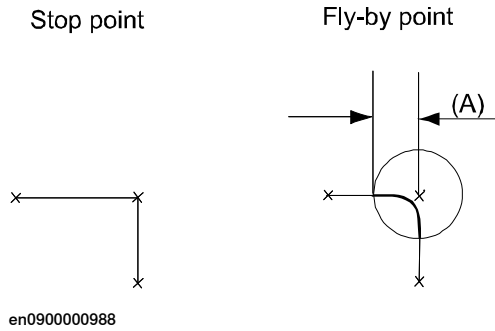

Pos	Description
A	User definable distance (in mm).

Velocity

The velocity may be specified in the following units:

- mm/s
- seconds (time it takes to reach the next programmed position)
- degrees/s (for reorientation of the tool or for rotation of an additional axis)

Program management

For convenience, the programs can be named and stored in different directories. The mass memory can also be used for program storage. Programs can then be automatically downloaded using a program instruction. The complete program or parts of programs can be transferred to/from the network or a portable flash memory connected to a USB port.

The program is stored as a normal PC text file, which means that it can be edited using a standard PC.

Editing programs

Programs can be edited using standard editing commands, that is, cut-and-paste, copy, delete, etc. Individual arguments in an instruction can also be edited using these commands.

A robot position can easily be changed either by:

- jogging the robot with the joystick to a new position and then pressing *Modify Position* (this registers the new position)
- entering or modifying numeric values

To prevent unauthorized personnel from making program changes, passwords can be used.

Testing programs

Several helpful functions can be used when testing programs. For example, it is possible to:

- start from any instruction
- execute an incomplete program
- run a single cycle

Continues on next page

- execute forwards/backwards step-by-step
- simulate wait conditions
- temporarily reduce the speed
- change a position

For more information, see *Operating manual - IRC5 with FlexPendant* and *Operating manual - RobotStudio*.

1 Description of the IRC5 controller

1.6.2 Automatic operation

1.6.2 Automatic operation

General

A dedicated production window with commands and information required by the operator is displayed during automatic operation.

The operation procedure can be customized to suit the robot installation by means of user-defined displays and dialogs.

The robot can be ordered to go to a service position when a specific signal is set. After service, the robot is ordered to return to the programmed path and continue program execution.

Special routines

You can also create special routines that will be automatically executed when the power is switched on, at program start and on other occasions. This allows you to customize each installation and to make sure that the robot is started up in a controlled way.

Absolute measurement

The robot is equipped with absolute measurement, making it possible to operate the robot directly when the power is switched on. For your convenience, the robot saves the used path, program data and configuration parameters so that the program can be easily restarted from where you left off. Digital outputs are also set automatically to the value prior to the power failure if this behavior has been selected.

1.6.3 RAPID language and environment

General

The RAPID language is a well balanced combination of simplicity, flexibility and power. It contains the following concepts:

- Hierarchical and modular program structure to support structured programming and reuse
- Routines can be Functions or Procedures
- Local or global data and routines
- Data typing, including structured and array data types
- User defined names on variables, routines and I/O
- Extensive program flow control
- Arithmetic and logical expressions
- Interrupt handling
- Error handling (for exception handling in general, see [Exception handling on page 84](#))
- User defined instructions (appear as an inherent part of the system)
- Backward handler (user definition of how a procedure should behave when stepping backwards)
- Many powerful built-in functions, for example mathematics and robot specific
- Unlimited language (no max. number of variables etc., only memory limited). Built-in RAPID support in user interfaces, for example user defined pick lists, facilitate working with RAPID

1 Description of the IRC5 controller

1.6.4 Exception handling

1.6.4 Exception handling

General

Many advanced features are available to make fast error recovery possible. The error recovery features easily adapt to a specific installation in order to minimize down time.

Examples

- Error Handlers (automatic recovery often possible without stopping production)
- Restart on Path
- Power failure restart
- Service routines
- Error messages: plain text with remedy suggestions, user defined messages
- Diagnostic tests
- Event logging

1.6.5 Robot motion

QuickMove™

The QuickMove™ concept means that a self-optimizing motion control is used. The robot automatically optimizes the servo parameters to achieve the best possible performance throughout the cycle - based on load properties, location in working area, velocity and direction of movement.

- No parameters have to be adjusted to achieve correct path, orientation and velocity.
- Maximum acceleration is always obtained (acceleration can be reduced, for example when handling fragile parts).
- The number of adjustments that have to be made to achieve the shortest possible cycle time is minimized.

TrueMove™

The TrueMove™ concept means that the programmed path is followed - regardless of the speed or operating mode - even after a safeguarded stop, a process stop, a program stop or a power failure.

This very accurate path and speed are based on advanced dynamic modelling.

Continues on next page

1 Description of the IRC5 controller

1.6.5 Robot motion

Continued

Coordinate systems

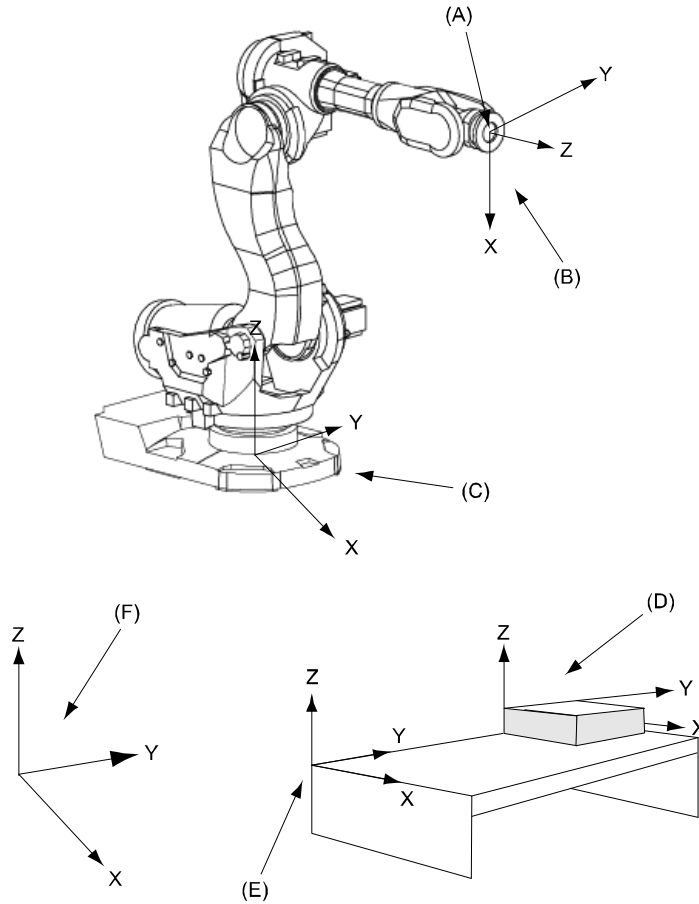

xx0900000985

Pos	Description
A	Tool Center Point (TCP)
B	Tool coordinates
C	Base coordinates
D	Object coordinates
E	User coordinates
F	World coordinates

System	Description
Coordinate systems	RobotWare includes a very powerful concept of multiple coordinate systems that facilitates jogging, program adjustment, copying between robots, off-line programming, sensor based applications, additional axes co-ordination etc. Full support for TCP (Tool Center Point) attached to the robot or fixed in the cell ("Stationary TCP").
World coordinate system	The world coordinate system defines a reference to the floor, which is the starting point for the other coordinate systems. Using this coordinate system, it is possible to relate the robot position to a fixed point in the workshop. The world coordinate system is also very useful when two robots work together or when using a robot carrier.

Continues on next page

System	Description
Base coordinate system	The base coordinate system is attached to the base mounting surface of the robot.
Tool coordinate system	The tool coordinate system specifies the tool's center point and orientation.
User coordinate system	The user coordinate system specifies the position of a fixture or workpiece manipulator.
Object coordinate system	<p>The object coordinate system specifies how a workpiece is positioned in a fixture or workpiece manipulator.</p> <p>The coordinate systems can be programmed by specifying numeric values or jogging the robot through a number of positions (the tool does not have to be removed).</p> <p>Each position is specified in object coordinates with respect to the tool's position and orientation. This means that even if a tool is changed because it is damaged, the old program can still be used, unchanged, by making a new definition of the tool.</p> <p>If a fixture or workpiece is moved, only the user or object coordinate system has to be redefined.</p>
Stationary TCP	When the robot is holding a work object and working on a stationary tool, it is possible to define a TCP for that tool. When that tool is active, the programmed path and speed are related to the work object.
Program displacement	If the location of a workpiece varies from time to time, the robot can find its position by means of a digital sensor. The robot program can then be modified in order to adjust the motion to the location of the part.

Additional features

System	Description
Program execution	<p>The robot can move in any of the following ways:</p> <ul style="list-style-type: none"> • Joint motion (all axes move individually and reach the programmed position at the same time). • Linear motion (the TCP moves in a linear path). • Circle motion (the TCP moves in a circular path).
Soft servo	<p>Soft servo - allowing external forces to cause deviation from programmed position - can be used as an alternative to mechanical compliance in grippers, where imperfection in processed objects can occur.</p> <p>Any motors (also additional) can be switched to soft servo mode, which means that it will adopt a spring-like behavior.</p>
Jogging	<p>The robot can be manually operated in any one of the following ways:</p> <ul style="list-style-type: none"> • Axis-by-axis, that is one axis at a time. • Linearly, that is the TCP moves in a linear path (relative to one of the coordinate systems mentioned above). • Reoriented around the TCP. <p>It is possible to select the step size for incremental jogging. Incremental jogging can be used to position the robot with high precision, since the robot moves a short distance each time the joystick is moved.</p> <p>During manual operation, the current position of the robot and the additional axes can be displayed on the FlexPendant.</p>

Continues on next page

1 Description of the IRC5 controller

1.6.5 Robot motion

Continued

System	Description
Singularity handling	The robot can pass through singular points in a controlled way, that is points where two axes coincide.
Motion supervision	The behavior of the motion system is continuously monitored in regards to position and speed level to detect abnormal conditions and quickly stop the robot if something is not OK. A further monitoring function, Collision Detection, is optional (see option <i>Collision Detection</i> , described in <i>Product specification - Controller software IRC5</i>).
Additional motors	Very flexible possibilities to configure additional motors. Includes for instance high performance coordination with robot movement and shared drive unit for several motors.
Big inertia	One side effect of the dynamic model concept is that the system can handle very big load inertias by automatically adapting the performance to a suitable level. For big, flexible objects it is possible to optimize the servo tuning to minimize load oscillation.
Load identification	The robot can automatically identify the load properties and thus ensures a correct dynamic model of the total arm system. This leads to optimum performance and life time, without need for cumbersome manual calculations or measurements. Load identification is available for most robots, and positioners IRBP. For more information, see <i>Operating manual - IRC5 with FlexPendant</i> .

1.7 Additional safety options

1.7.1 Electronic Position Switches [810-1]

General

Electronic Position Switches (EPS) is an additional safety computer in the controller, with the purpose of providing safe output signals representing the position of robot axes. The output signals are typically connected to cell safety circuitry and/or a safety PLC which takes care of interlocking the robot cell, for example in order to prevent robot and operator to enter a common area simultaneously. See *Application manual - Electronic Position Switches*.

Features

- Safety classification according to EN 954-1: Category 3
- Supervision of all robot axes.
- No installation on manipulator.
- 5 safe outputs, representing status for signal axis or a combination of axes.
- Safe input from a synchronization switch for repeated checks during production
- Access to status of safe outputs from RAPID, without any wiring
- EPS replaces mechanical position switches

Option content

The following is included with the option delivery

- The safety computer unit, installed close to the axis computer
- A 14 pole connector plug for I/O connection.
- EPS Configuration Wizard, add-in software to RobotStudio. With EPS Configuration Wizard you can:
 - Set up supervision of all robot axes
 - Quickly modify the supervision settings (password protected)
 - Print a safety certificate

Limitations

- Additional axis, including track motion, positioners etc. connected to measurement link 2 can not be supervised.
- Continuous rotation axes cannot be supervised.
- Drive unit cannot be shared for supervised axes, for example between tools.
- Not available for all robots, see the product specification for the respective robot.
- Not available for non IRB mechanical units.
- Not available for 700-5, 700-6 Panel Mounted Controller.
- Not available for option 429-1 UL/CSA certified.

1 Description of the IRC5 controller

1.7.2 SafeMove [810-2]

1.7.2 SafeMove [810-2]

Purpose

SafeMove is a safety controller in the robot system. The purpose of the safety controller is to ensure a high safety level in the robot system using supervision functions that can stop the robot and monitoring functions that can set safe digital output signals.

The supervision functions can be activated by safe digital input signals. Both input and output signals can be connected to, for instance, a safety PLC that can control which behavior is allowed for the robot at different times.

The safety controller also sends status signals to the main computer, that is the standard IRC5 robot controller.

Note that *SafeMove* is one component in a cell safety system, normally complemented by other equipment, e.g. light barriers, for detecting the whereabouts of the operator.

Some examples of applications:

- Manual loading of gripper
- Manual inspection in robot cell during operation
- Optimization of cell size
- Protection of sensitive equipment
- Ensuring safe orientation of emitting processes

What is included

The following is included with the option *SafeMove* [810-2]:

- Safety controller, DSQC 647 (3HAC026272-001)
- Two 12 pole plug contacts and two 10 pole plug contacts for I/O connections.

The option *SafeMove* gives you access to *SafeMove* Configurator functionality in RobotStudio.

With *SafeMove* Configurator you can:

- configure supervision functions (active supervision that can stop the robot)
- configure activation signals for the supervision functions
- configure monitoring functions (passive monitoring, only sets output signals)
- configure output signals for the monitoring functions
- easily modify the configuration

Supported robots

The following robot families are supported by *SafeMove*1:

- IRB 140
- IRB 260
- IRB 460
- IRB 660
- IRB 760
- IRB 1400

Continues on next page

- IRB 1600/1660
- IRB 2400
- IRB 2600
- IRB 4400
- IRB 4600
- IRB 6620
- IRB 6640
- IRB 6660
- IRB 6650S
- IRB 6700
- IRB 6790
- IRB 7600
- IRB 8700

Other robot models are not supported.

SafeMove cannot be used for parallel arm robots, such as IRB 360.

SafeMove can only be used together with floor mounted robots.

Limitations

- Not available for 700-8 IRC5 Compact.
- Not available for 700-5, 700-6 Panel Mounted Controller.
- Not available for option 429-1 UL/CSA certified.

Supported additional axes

Basically the SafeMove option only supports ABB track motion units.

Non ABB track motion units, non ABB positioners, and other additional axis may be supported by the SafeMove option but this needs to be verified case by case.

The SafeMove option only supports additional axes that are single axis mechanical units. For example, two axes positioners cannot be supported.

Further, there are always the following upper and lower work area limitations:

- Track unit length (arm side) max ± 100 m
- Rotating axis (arm side) max $\pm 25\ 700$ degrees or ± 448 radians

On the motor side there is also a limitation of $\pm 32\ 000$ revolutions.

Stand alone controller

Stand alone controller or drive module without TCP-robot, are not supported by SafeMove.

Servo welding gun

SafeMove does not support supervision of servo welding guns. That is, the robot axes can be supervised, but not the axis of the servo welding gun.

Continues on next page

1 Description of the IRC5 controller

1.7.2 SafeMove [810-2]

Continued

Tool changer

SafeMove supports up to 4 different tools. All included tools must have their appropriate settings in the configuration file. Selection of tool to be supervised is done by 2 binary coded safe inputs on SafeMove.

Robot mounted on rotational axis

SafeMove does not support supervision or monitoring of a robot mounted on a rotational axis.

No deactivation

All supervised and monitored axes must be active all the time. SafeMove does not support activation/deactivation of additional axis.

The ABB positioners normally use the activation/deactivation feature and therefore they are not supported by SafeMove.

Independent joint

Independent joint cannot be monitored by SafeMove.

Shared drive modules

Drive units of supervised and monitored axes cannot be shared, for instance between positioner axes.

Track motion coordinates

When a robot is mounted on a track motion, the following limitations apply:

- It is only possible to define a rotation (no translation) of the robot base frame relative the track motion base frame.
- It is only possible to define a translation (no rotation) of the track motion base frame relative the world frame.

Limit switch override cannot be used

If the option SafeMove is used, it is not allowed to connect any signal to the limit switch override (X23 on the contactor board).

RAPID non motion execution

This test feature cannot fully be used together with the SafeMove option.

Borderline positions

In very rare cases an error message, eLog 20473, might be presented if the robot is stopped for a time longer than 40 min in a position exactly on the border of the defined range. This is because of the internal safe design of the SafeMove controller, using a safe two channel microprocessor solution.



Tip

To avoid this, never leave the robot for a longer period in a position near the borders of Monitor Axis Range.

Continues on next page

Alternative calibration position

The alternative calibration position, which can be used for robots and additional axes, is not supported by SafeMove. The calibration position shall be defined to zero position.



Note

Calibration position is set in the system parameter *Calibration Position*, which is found under topic *Motion* and type *Arm*.

MultiMove

It is not supported to use a mixture of EPS (Electronic Position Switches) and SafeMove in a MultiMove installation. However, robots can be used with or without SafeMove in a mixed setup.

1 Description of the IRC5 controller

1.7.3 SafeMove Basic [1125-1] and SafeMove Pro [1125-2]

1.7.3 SafeMove Basic [1125-1] and SafeMove Pro [1125-2]

Purpose

The purpose of the functional safety options is to provide easy-to-use safety functions in the robot. Functional safety includes a complete software and hardware solution that is fully integrated with the robot controller and the RobotStudio programming environment.

SafeMove is the main functional safety option, but the safety module can also be used in various applications without the SafeMove option. For example to communicate with a safety PLC through safe fieldbus communication, or when using the keyless mode selector.

SafeMove functions

SafeMove ensures a high safety level in the robot by using supervision functions that can stop the robot. Note that the functional safety options is one component in the safety system of a complete robot cell, normally complemented by other equipment (for example light barriers) for detecting the whereabouts of the operator.

Function	Description
Tool supervision functions	Protects the operator and enhances machine and equipment safety by supervising the position (<i>Tool Position Supervision</i>), speed (<i>Tool Speed Supervision</i>) and orientation (<i>Tool Orientation Supervision</i>) of the tool.
Axis supervision functions	Protects the surroundings by supervising the axis position (<i>Axis Position Supervision</i>) and the axis speed (<i>Axis Speed Supervision</i>).
Stand Still Supervision	Supervises the stand-still of robot axes without having to switch the robot to Motors Off. It enables operators to perform tasks in the immediate vicinity of the robot.
Contact application tolerance	Allows the robot to be in contact with the work-piece in limited areas. This can for example be used in applications where the robot is used for grinding or during tool change.
Cyclic brake check	Supervises that the brakes are checked with a cyclic interval.
Stop functions	Triggers stop of the robot using safe fieldbus inputs from the safety PLC.

Some examples of applications:

- Manual loading stations
- Manual workpiece inspection during operation
- Optimization of cell size
- Protection of sensitive equipment
- Ensuring safe orientation of emitting processes

Functional safety options

To use SafeMove or any of the functional safety options it is necessary to have the safety module in the IRC5 controller:

- [996-1] *Safety module (DSQC1015)*

The following options can be ordered together with the safety module:

- [997-1] *PROFIsafe F-Device*

Continues on next page

- [997-2] *PROFIsafe F-Host&Device*
- [997-3] *CIP Safety Adapter*
- [997-4] *CIP Safety Scanner And Adapter*
- [1241-1] *Prepared for ABB CI502*
- [1125-1] *SafeMove Basic*
- [1125-2] *SafeMove Pro*
- [735-7] *Keyless Mode Selector, 3 modes*
- [735-8] *Keyless Mode Selector, 2 modes*
- [731-1] *Safety Internal conn.*
- [731-2] *Safety external conn.*

Visual SafeMove

The safety module option gives you access to the Visual SafeMove configurator in RobotStudio. With Visual SafeMove you can:

- configure and visualize supervision functions in a 3D environment.
- configure stop functions, such as automatic stop.
- configure Cyclic Brake Check.
- configure safe signals (safe Ethernet communication and I/Os are configured in *I/O Engineering Tool*).
- configure signal logics.
- configure system status outputs.

SafeMove Basic and SafeMove Pro

The below table lists the differences between SafeMove Basic and SafeMove Pro.

Function	SafeMove Basic	SafeMove Pro
Supported number of axes	9	9
Safe ranges	8	8
Safe zones	1	16
Tool changer support	-	16 tools
Axis Position Supervision	Yes	Yes
Axis Speed Supervision	-	Yes
Total Global Supervision	8	8
Tool Orientation Supervision	-	Yes
Tool Position Supervision	1	Yes
Tool Speed Supervision	-	Yes
Stand Still Supervision	-	Yes
Contact application support	Yes	Yes

Basic approach

This is the general approach for setting up the safety module and SafeMove.

- 1 Connect the safety controller to other safety hardware and configure the safe I/O connections.

Continues on next page

1 Description of the IRC5 controller

1.7.3 SafeMove Basic [1125-1] and SafeMove Pro [1125-2]

Continued

- 2 Configure the settings for the SafeMove functions.
- 3 Download the configuration to the the safety controller. Restart the controller.
- 4 Synchronize the safety controller.
- 5 Make sure the activation input signals are activating the desired supervision functions.
- 6 Validate the configuration.
- 7 Lock the configuration.

Requirements

Robust supervision functionality in SafeMove requires correct settings of payload and additional axes, since this will affect the calculated accepted servo lag. Also note that external forces applied on the manipulator can cause a negative influence on the supervision functions, since the servo lag might differ from the calculated values, due to such external forces.



DANGER

A SafeMove configuration must always be validated to verify that the desired safety is achieved. If no validation is performed, or the validation is inadequate, the configuration cannot be relied on for personal safety.

The validation must also consider that the braking starts after a zone is violated, so additional stopping distances may be required, which depend on many factors, for example mass and speed.

Continues on next page

Supported controller variants

The safety module is available for the following controller variants:

- Single controller [700-3]
- Compact controller [700-8]
- Panel Mounted controller [700-5] & [700-6]



Note

For Panel Mounted Controller with SafeMove2, the control module and the primary drive module must be located together.

Robots supported by the safety module

The safety module, without a SafeMove option, supports all ABB robots that can be ordered with the above controller variants.

Safe fieldbus options

The safe fieldbus options can be used on all robots that supports the safety module.

Keyless mode selector options

The keyless mode selector options are available for the following controller variants:

- Single controller [700-3]

Robots supported by SafeMove

From RobotWare 6.15 the following robot families are supported by SafeMove - under the condition that the robot version is supported by RobotWare 6.15:

- IRB 140/140T
- IRB 260
- IRB 460
- IRB 660
- IRB 760
- IRB 1200
- IRB 1400
- IRB 1510
- IRB 1520ID
- IRB 1600/1660
- IRB 2400
- IRB 2600
- IRB 4400
- IRB 4600
- IRB 6600
- IRB 6620
- IRB 6640
- IRB 6650

Continues on next page

1 Description of the IRC5 controller

1.7.3 SafeMove Basic [1125-1] and SafeMove Pro [1125-2]

Continued

- IRB 6650S
- IRB 6660
- IRB 6700/6700Inv
- IRB 6790
- IRB 7600
- IRB 8700



Note

In MultiMove systems with SafeMove pro/basic, robot IRB 1200 type A cannot be included. The option SafeMove will be excluded for all robots in the system even if they are supported by SafeMove.



Note

This also includes ID and LeanID versions.



Note

For information on supported paint robots, see *Application manual - Functional safety and SafeMove for paint*.



Note

Other robot models are not supported, for example:

- SafeMove does not support parallel arm robots, such as the IRB 360.



Note

For robots not supported by SafeMove, be aware that in a MultiMove setup only the supported robots can be supervised which means that you need to have a supported robot as the main product.

In the Safety configuration, exclude not supported robots with the setting *Exclude from configuration*.

For more information, see *Application manual - Functional safety and SafeMove2*.

Supported mounting angles

SafeMove supports any mounting angle. For example floor mounted, tilted, inverted, etcetera.

Supported tracks

SafeMove supports all ABB track motion units.

Continues on next page

Supported positioners

SafeMove supports positioners that are single axis mechanical units. Positioners with several axes are treated as multiple single axes, for example two axes positioners will be treated by SafeMove as two single axes and can be monitored as such using axis supervision.

Positioners that are used with activation/deactivation feature, is not supported. The axes of the positioner must be active at all times.

Servo welding gun

SafeMove does not support supervision of servo welding guns. That is, the robot axes can be supervised, but not the axis of the servo welding gun.

Non ABB additional axes

Non ABB track motion units, non ABB positioners, and other additional axis may be supported by the SafeMove option but this needs to be verified case by case.

To verify if a non ABB additional axis can be used with SafeMove, tune the additional axis before configuring the SafeMove parameters. If a properly tuned and configured non ABB additional axis still generates error messages regarding servo lag, then it cannot be used with SafeMove. For more information about tuning an additional axis see *Application manual - Additional axes and standalone controller*.

Work area for additional axes

There are always the following upper and lower work area limitations for additional axes:

- Track unit length (arm side) max ± 448 m
- Rotating axis (arm side) max ± 25700 degrees or ± 448 radians

On the motor side there is also a limitation of ± 32000 revolutions.

Combined external axes and robot with gantry

SafeMove does not support supervision of combined external axes, such as a gantry, or supervision of robots moved by the gantry.

It is possible to supervise robots moved by a gantry using the Basic joint supervision mode. In Basic joint supervision mode, only SafeMove functions working on axes are available.

Basic joint supervision mode

In Basic joint supervision mode, SafeMove supports supervision of some robots and external axes that are not normally allowed. Examples are robots mounted on a gantry, or other non-track external axes.

In Basic joint supervision mode, no safe zones or tool supervision functions are allowed. In addition, there are changes to some internal SafeMove supervision functions:

- The manual mode speed supervision of the TCP, wrist center point, and elbow are disabled. Instead, axis speed limits are set to approximate a Cartesian speed limit. The user is responsible for validating that this speed limit satisfies the requirements for safe manual mode operation.

Continues on next page

1 Description of the IRC5 controller

1.7.3 SafeMove Basic [1125-1] and SafeMove Pro [1125-2]

Continued

- The Safe Brake Ramp supervision for the robot during a category 1 stop is changed, so that SafeMove supervises that all robot axes will stop within 1 second.

Stand alone controller

SafeMove supports *Stand alone controller* and drive modules without TCP-robot with up to six additional axes. The axes are handled as external single axis.

Only SafeMove functions working on axes are available. The functions are:

- Axis Position Supervision (APO)
- Axis Speed Supervision (ASP)
- Stand Still Supervision (SST)
- Safe Brake Ramp

All other functions are deactivated.

Tool changer

SafeMove Pro supports up to 16 different tools. All included tools must have their appropriate settings in the configuration file. The selection of tool must be supervised using a safe fieldbus.

Robot mounted on rotational axis

SafeMove does not support supervision of a robot mounted on a rotational axis. Using the Basic joint supervision mode, axis monitoring will be possible but the tool supervision functions are not supported.

No deactivation

Additional axes that are used with activation/deactivation feature are not supported. If additional axes are to be used, they must also be active at all times.

Independent joint

Independent joint cannot be monitored by SafeMove.

Electronically linked motors

SafeMove supports supervision of additional axes using Electronically Linked Motors. Using this feature may cause servo lag problems, particularly if the follower axis is included in the safety configuration. It may be necessary to modify the tuning of the axes, or increase the tolerances in the SafeMove configuration. The performance should be verified case by case.

Shared drive modules

Drive units of supervised axes cannot be shared, for instance between positioner axes.

Superior Stop

If the safety module is used, it is not allowed to connect any signal to the Superior Stop input on the Panel Board.

Continues on next page

If the safety module is used, the configured value for the parameter *Soft Superior Stop* (*SoftSS*) is ignored and Superior Stop will always use a category 0 stop.

RAPID non motion execution

This test feature cannot fully be used together with the SafeMove option.

SoftMove

When SafeMove is used together with SoftMove there is a risk for servo lag problems. The recommended action is to add a Contact Application Tolerance (CAP) in the area where SoftMove is active.

For more information about SoftMove, see *Application manual - Spot options* and *Application manual - SoftMove*.

This page is intentionally left blank

2 Specification of variants and options

2.1 Introduction to variants and options

General

The different variants and options for the controller are described below. The same option numbers and structure are used here as in the specification form.

For details about manipulator options, see the product specification for the respective manipulator.

For software options, see *Product specification - Controller software IRC5*.

2 Specification of variants and options

2.2.1 Controller variants

2.2 Basic

2.2.1 Controller variants

Drive module [700-1]

Additional drive modules can be ordered together with the single controller to control additional axes or additional robots, MultiMove.

Up to three additional axes can be controlled by each drive module, and up to three additional drive modules can be connected.

For more information, see section [Drive module on page 144](#).

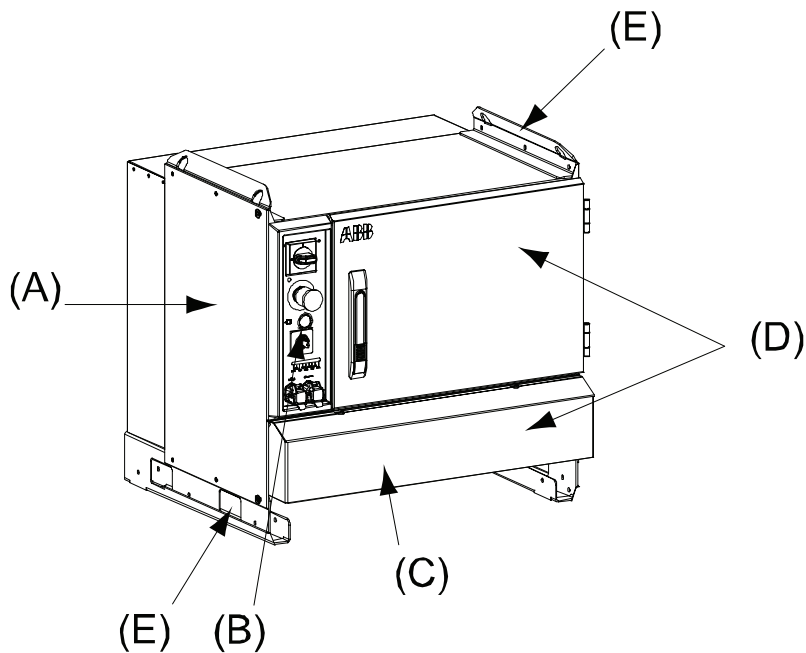

xx150000255

A	Controller color	Aluzink
B	Operator's panel	
C	Connector covers	All cable connections at the front, optional covered
D	Controller color, door and connector covers	NCS 2502 B (light grey)
E	Controller color, feet and lifting eyes	Black

Data	Weight
Drive module	100-130 kg
Empty cabinet small	35 kg
Empty cabinet large	42 kg

Data	Volume (H x W x D)
Drive module small	720 x 725 x 710 mm

Continues on next page

2 Specification of variants and options

2.2.1 Controller variants

Continued

Single cabinet [700-3]

This option is the standard selection for all robots, also for a MultiMove main robot.

For more information, see section [Control module on page 120](#).

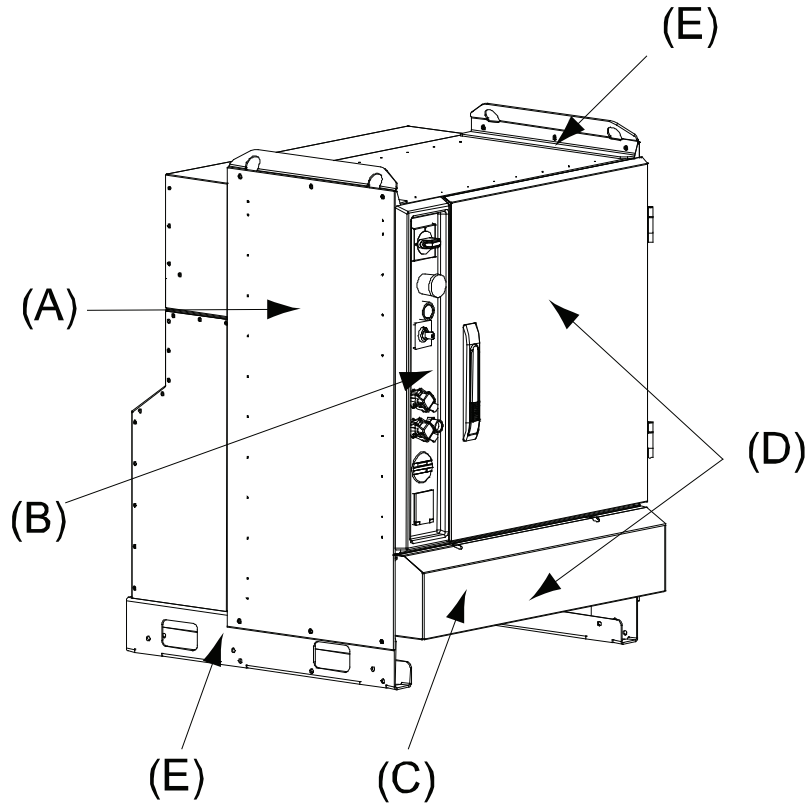

xx1300000791

A	Controller color	Aluzink
B	Operator's panel	
C	Connector covers	All cable connections at the front, optional covered
D	Controller color, door and connector covers	NCS 2502 B (light grey)
E	Controller color, feet and lifting eyes	Black

Data	Weight
Single cabinet controller	max 150 kg

Data	Volume (H x W x D)
Single cabinet controller	970 x 725 x 710 mm
Empty cabinet large	

Continues on next page

2 Specification of variants and options

2.2.1 Controller variants

Continued

Panel Mounted Controller [700-5]

The IRC5 Panel Mounted Controller (PMC), is a concept where the controller can be mounted in a customer cabinet for example when there are special demands on size reduction or hygienic encapsulation.

For MultiMove applications the robot can be ordered with only the drive module. Two versions of Panel Mounted Controller are available, depending on robot version and size, PMC Small and PMC Large. The difference is the size of drive units in the Drive module.

For more information, see [Controller variants on page 11](#).

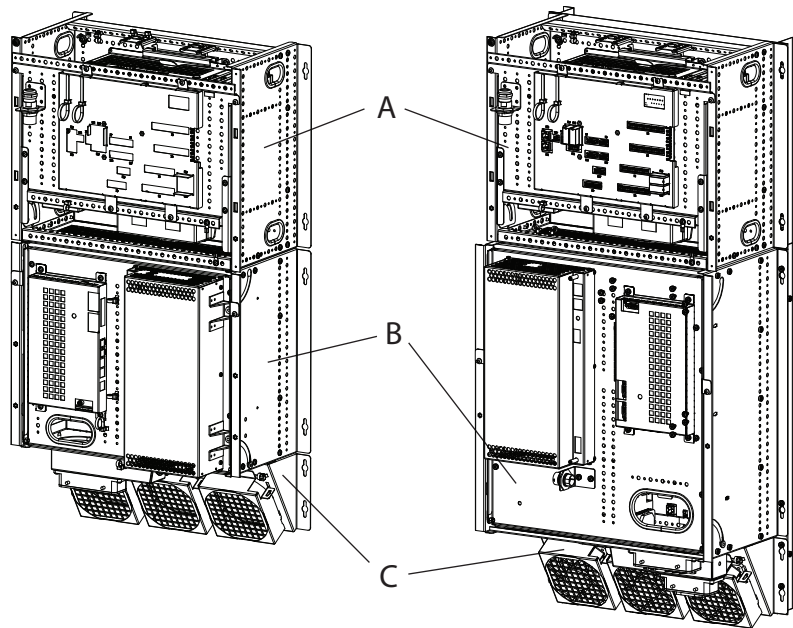

xx110000484

A	Control Module
B	Drive Module (different design for PMC small and PMC large)
C	Fan unit (for PMC large this is a part of the Drive Module)

Panel Mounted Drive unit [700-6]

Additional drive module for Panel Mounted Controller, small or large. This controller is intended for integration in customer equipment.

For more information, see [Controller variants on page 11](#).

Continues on next page

Compact controller 2nd generation [700-8]

Available for IRB 140, 1200, 1600, 260 and 360.

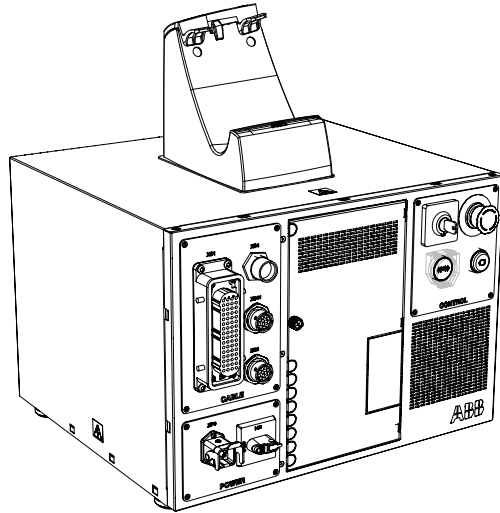

xx1400001368

Data	Volume (H x W x D)
Compact controller	310 x 449 x 442 mm

For more information see section [IRC5 Compact controller on page 29](#).

IRC5C controller mounting kit [984-1]

Enables controller to be mounted in std. 19 inch rack enclosure

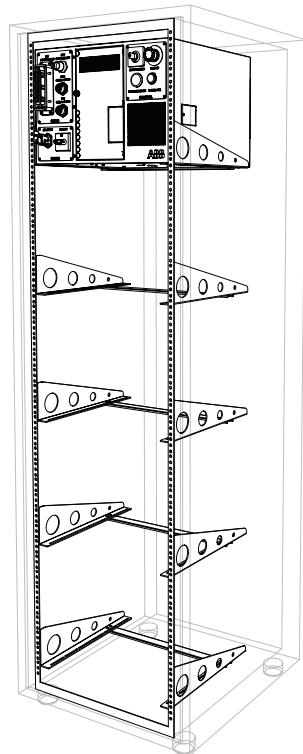

xx1400002112

2 Specification of variants and options

2.2.1 Controller variants

Continued

Underwriters Laboratory [429-1]

UL/CSA

The robot and the control system are certified by Underwriters Laboratories to comply with the Safety Standard ANSI/UL 1740-1998 Industrial Robots and Robotic Equipment and CAN/CSA Z 434-94. Law for UL/CSA certification is required in some US states and Canada.

UL (UL listed) means certification of the complete robot product. The option is visualized by a “UL” label attached to the cabinet.



Note

Note that the variant Panel Mounted Controller is labelled UR (UL recognized) as standard

Other required options:

- Safety lamp on the manipulator arm (213-1)
- Door interlock (744-1 or 742-1)
- Operating mode selector limited speed max 250 mm/s (735-2 or 735-4 or 735-8)
- If optional service outlet is desired, 120V must be selected (736-2)

Prepared for CE and China [129-1]

The option 129-1 consists of a line filter to prevent radio noise emission to the incoming power. Note that the filter is included in the variants PMC and Compact. Note that the filter component for large robots is not specified for more than 525 Vac. Thus it is not possible to use together with 600 V line voltage.

For small robots it is not specified for more than 480 Vac. Thus it is not possible to use together with 500 and 600 V line voltage. Another limitation for small robots is that together with Drive module only (700-1) there is not space enough for the option 744-1 Door interlock.

The certifying document “Declaration of incorporation of partly completed machinery” (which from November 2009 is supplied with every control system) has a note which tells the machine integrator that the robot (part of a machine) has to be equipped with this option to be prepared for CE marking.



Note

The integrator/machine builder is responsible for CE-labelling of the robot cell before it is taken into operation within EU countries.

Transformer for Panel mounted [881-2]

PMC without transformer and circuit breaker.

2 Specification of variants and options

2.2.1 Controller variants

Continued

Main voltage [769]

The IRC5 controller can be connected to a rated voltage of between 200 V and 600 V, 3-phase and protective earthing.

The options below indicate the connection and labelling at delivery.

Option	Voltage labelling	Servo transformer included		
		IRB 1200 - 4400	IRB 4600, 660, 66XX, 6700	IRB 7600, 8700
769-7	200 V	Yes, Size 1, (4.2 kVA)	Yes, Size 5, (13 kVA)	Yes, Size 5
769-1	220 V	Yes, Size 1, (4.2 kVA)	Yes, Size 5, (13 kVA)	Yes, Size 5
769-2	400 V	Yes, Size 2, (4.2 kVA)	-	Yes, Size 5
769-3	440 V	Yes, Size 3, (4.2 kVA)	-	Yes, Size 5
769-4	480 V	Yes, Size 3, (4.2 kVA)	-	-
769-6	600 V	Yes, Size 3, (4.2 kVA)	Yes, Size 5, (13 kVA)	Yes, Size 5

Multi voltage transformer [931-1]

World transformer 6 kVA transformer for robots IRB 1200-4400.

Voltage range 200-600 V

2 Specification of variants and options

2.2.2 Mains connection type

2.2.2 Mains connection type

Mains connection, cable gland [752-1]

The customer power cable is routed via the cable gland (A) through a tube (C) up to the mains switch (B). Protective grounding PE (green/yellow cable) is connected directly to structure at (D).



Note

Basic option – no connector means low cost.

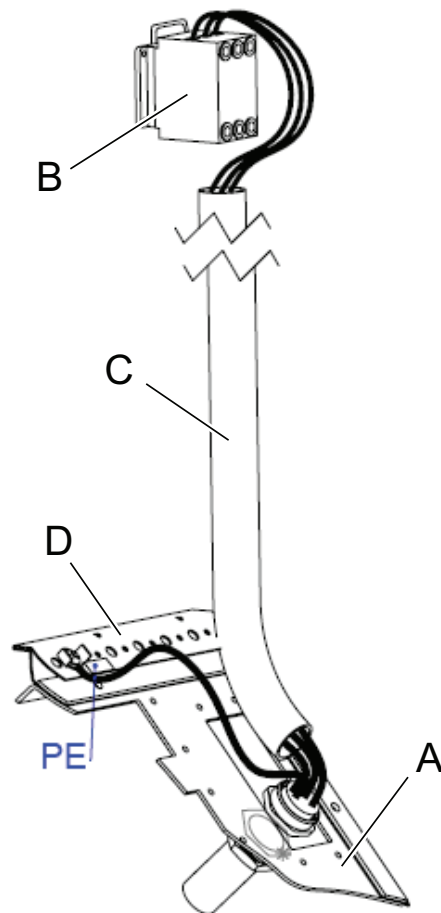

xx160000168

Mains connection, 6HSB 6p+PE [752-2]

Select when a quick power connection in cabinet end is desired, this option saves installation time and time for replacing cabinet.

The customer cable connector (Harting) is included. Compared to 752-1 the internal cable is already routed to the mains switch inside the cabinet.

2.2.3 Main switch

Rotary switch [742-1]

For Single cabinet there is only one switch. For MultiMove with several Drive modules the total power on/off is controlled from the main robot.

Rotary switch with padlocking possibility. Customer fuses at the distribution panel are required for short circuit protection of Drive module cabling.

See [Configuration on page 55](#).

Circuit breaker [743-1]

For Single cabinet there is only one switch. For MultiMove with several Drive modules the total power on/off is controlled from the main robot.

Circuit breaker for the rotary switch. The circuit breaker acts as overload protection of Drive module cabling for the case when customer fuses are >3x32A. For fuse selection see interrupt capacity table below. Max. customer fuse 3x80A.



Note

Not needed for 16 – 25A fuse (normal case). Selected only when customer fuses are >35A (fuse max. 80A due to internal cabling AWG10, 6 mm²).

Mains voltage	Interrupt capacity for option 743-1
200 V	100 kA
220 V	100 kA
400 V	50 kA
440 V	30 kA
480 V	22 kA
500 V	20 kA
600 V	10 kA

Door interlock [744-1]

Door interlock for rotary switch. A mechanical lock prevents door opening when the switch is in ON-position.



Note

Required by UL or customer requirement

2 Specification of variants and options

2.2.4 Controller cooling conditions

2.2.4 Controller cooling conditions

Room temperature

Max 45 C [708-1]

Basic selection allows room temperature up to 45C.

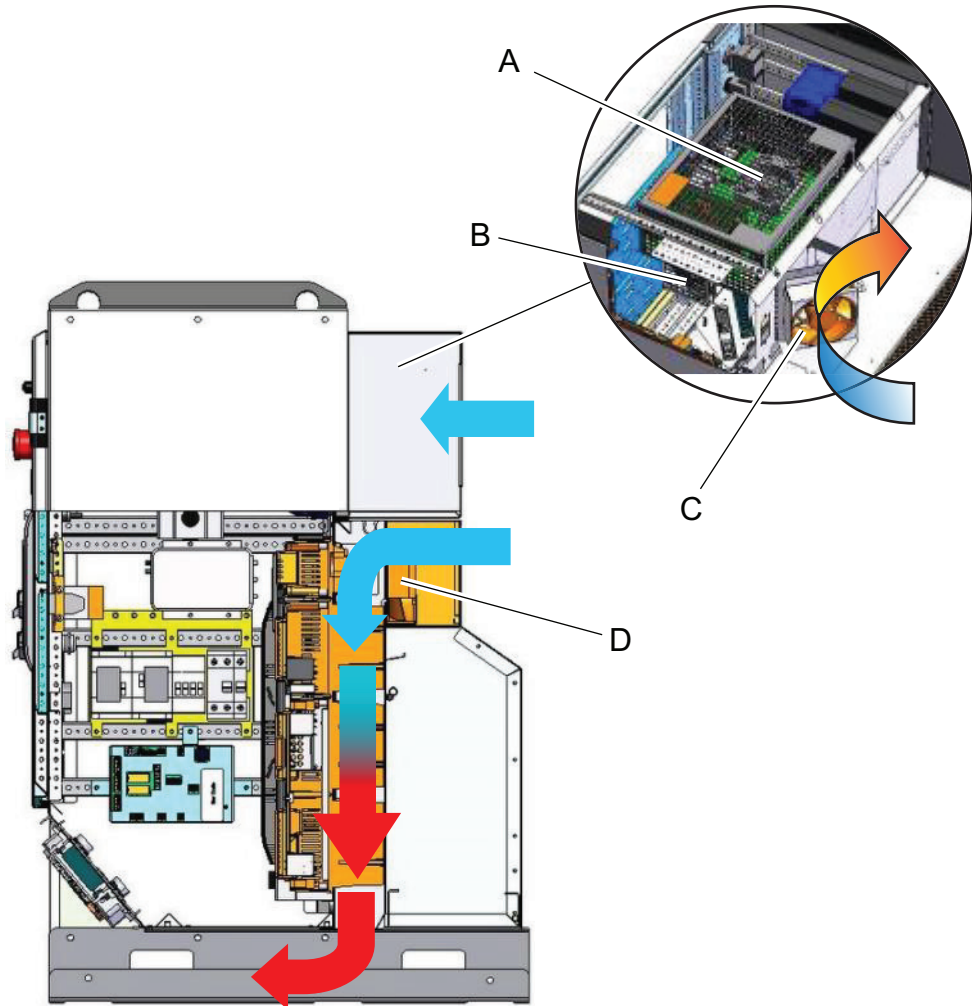

xx160000169

A	Internal air circulating, main computer fan
B	Internal air circulating, panel board fan
C	Computer section fan
D	Drive system: <ul style="list-style-type: none">• IRB 1200-4400, 2 fans• IRB 4600-7600, 3 fans

Continues on next page

Max 52 C [708-2]

Select when room temperature is expected to be higher than 45C but lower than 52C.

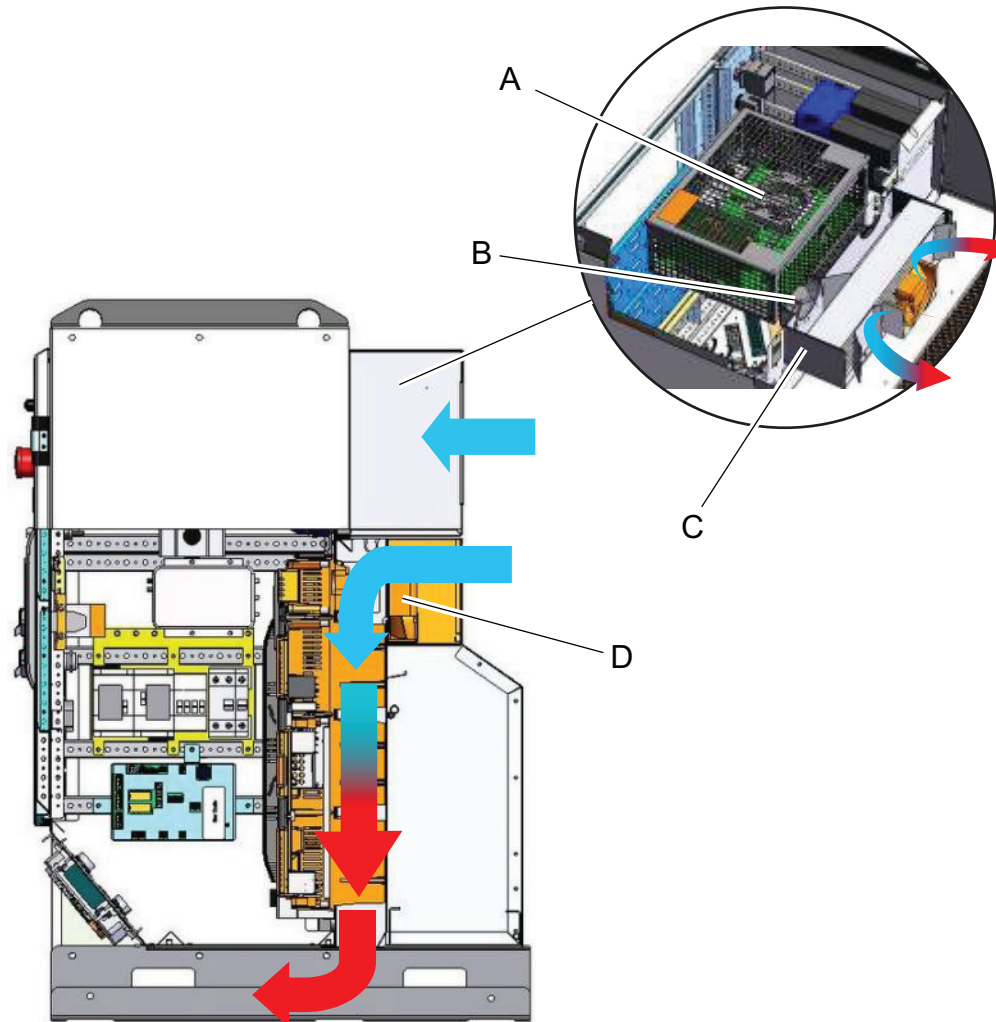

xx160000201

A	Internal air circulating, main computer fan
B	Internal air circulating, heat exchanger inside fan
C	Computer section fan, heat exchanger added
D	Drive system: <ul style="list-style-type: none"> • IRB 1200-4400, 4 fans • IRB 4600-7600, 4 fans, with increased capacity

Temperature Sensor Fan [1170-1]

Fans controlled by temperature sensor allowing fans to change rotational speed depending on ambient temperature and load of drive unit. This option reduces fans power consumption and noise level.

Continues on next page

2 Specification of variants and options

2.2.4 Controller cooling conditions

Continued

Available for Single controller (700-3) and Drive module only (700-1).



Note

Not available with Room temperature max 52 C (708-2).

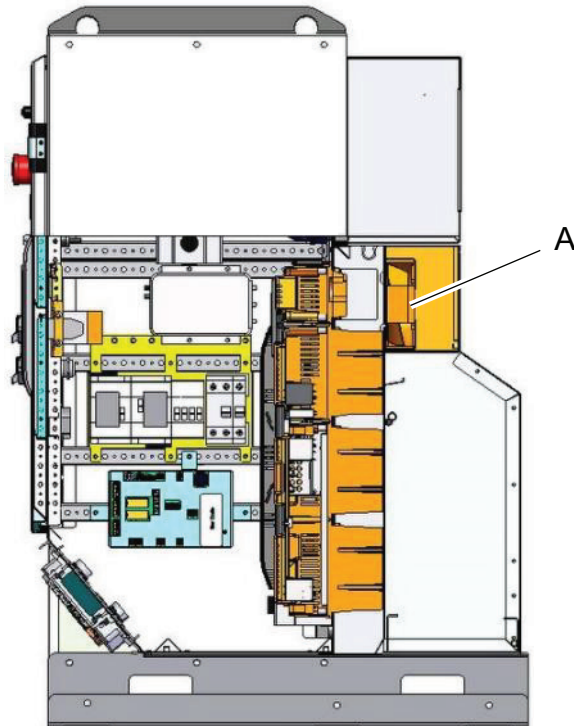

xx160000202

A	Fans controlled by temperature sensor
---	---------------------------------------

Fans for Panel Mounted Controller [882-1]

Fan unit including 3 fans (Included in PMC Large).

Cooling air filter

Ducts and fans are exposed to cooling air and are designed to reduce the need for maintenance in most applications.

Metal mesh filter [764-1]

Moist particles are prevented from entering the air ducts and fans by metal mesh filter.

Select when cooling air contains moist particles > 0.5 mm.

Polymeric filter [764-2]

Moist particles are prevented from entering the air ducts and fans by polymeric filter.

Select when cooling air contains moist dust.

Continues on next page

Cabinet connector protection [741-1]

Prevents front connectors from being damaged

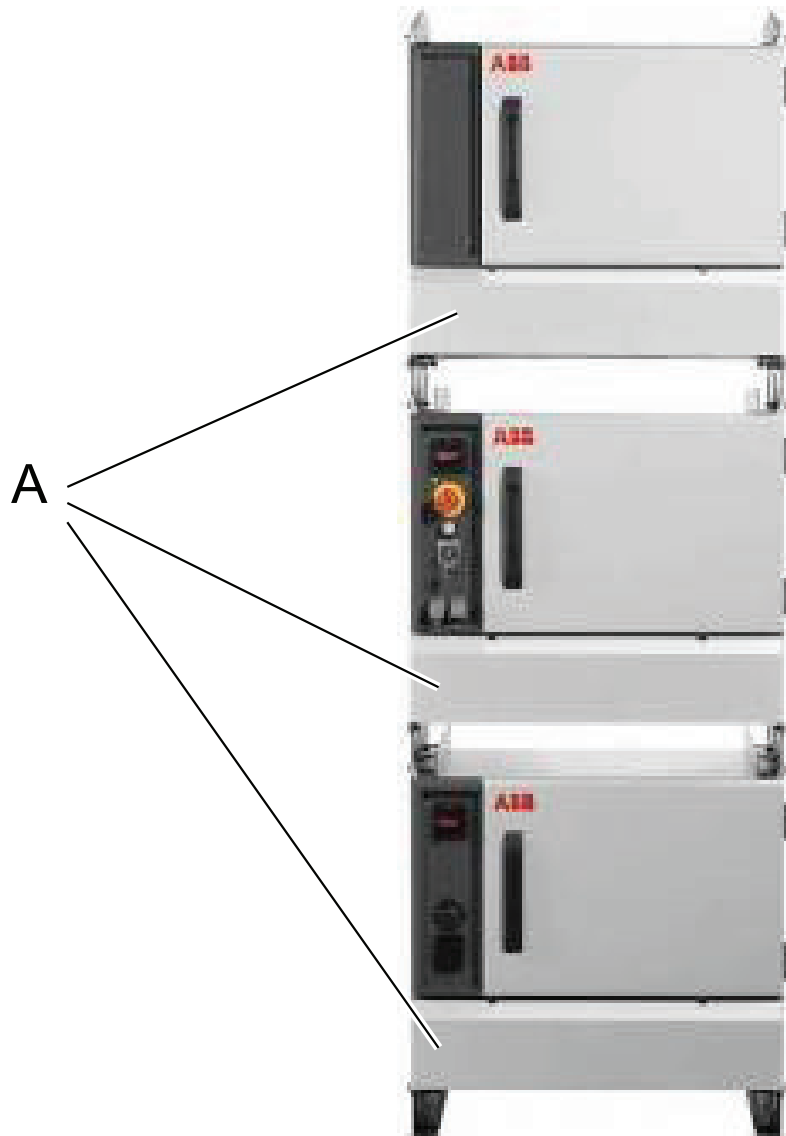

2 Specification of variants and options

2.2.5 Warranty

2.2.5 Warranty

Description

For the selected period of time ABB will provide spare parts and labour to repair or replace the nonconforming portion of the equipment without additional charges. During that period, it is required to have a yearly Preventative Maintenance according to ABBs manuals to be performed by ABB. If due to customer restrains no data can be analyzed in the ABB Ability Service “Condition Monitoring & Diagnostics” for robots with Omnicore controllers, and ABB has to travel to site, travel expenses are not covered. The Extended Warranty period always starts on the day of warranty expiration. Warranty Conditions apply as defined in the Terms & Conditions.



Note

This description above is not applicable for option *Stock warranty* [438-8]

Option	Type	Description
438-1	Standard warranty	Standard warranty is 12 months from <i>Customer Delivery Date</i> or latest 18 months after <i>Factory Shipment Date</i> , whichever occurs first. Warranty terms and conditions apply.
438-2	Standard warranty + 12 months	Standard warranty extended with 12 months from end date of the standard warranty. Warranty terms and conditions apply. Contact Customer Service in case of other requirements.
438-4	Standard warranty + 18 months	Standard warranty extended with 18 months from end date of the standard warranty. Warranty terms and conditions apply. Contact Customer Service in case of other requirements.
438-5	Standard warranty + 24 months	Standard warranty extended with 24 months from end date of the standard warranty. Warranty terms and conditions apply. Contact Customer Service in case of other requirements.
438-6	Standard warranty + 6 months	Standard warranty extended with 6 months from end date of the standard warranty. Warranty terms and conditions apply.
438-7	Standard warranty + 30 months	Standard warranty extended with 30 months from end date of the standard warranty. Warranty terms and conditions apply.
438-8	Stock warranty	<p>Maximum 6 months postponed start of standard warranty, starting from factory shipment date. Note that no claims will be accepted for warranties that occurred before the end of stock warranty. Standard warranty commences automatically after 6 months from <i>Factory Shipment Date</i> or from activation date of standard warranty in WebConfig.</p> <div data-bbox="798 1836 860 1897" data-label="Image"> </div> <div data-bbox="880 1850 946 1883" data-label="Section-Header"> <h4>Note</h4> </div> <div data-bbox="790 1904 1418 1962" data-label="Text"> <p>Special conditions are applicable, see <i>Robotics Warranty Directives</i>.</p> </div>

2.2.6 Connected Services enabled

WiFi/Internet [890-5]

The service box DSQC1023 WiFi (3HAC058038-001) can be connected only through Internet wired or wireless. It does not have modem and SIM holder.

This service box is used in large installations having Internet and is included with the following:

- Retrofit kit 1023 WiFi + Internet (3HAC058038-001)
- Remote Service 1023 WiFi + Internet Factory Option (890-5).

Connected Services 4G EU [890-6]

The option *Mobile network 4G EU* for Connected Services uses a 4G mobile network connection for transferring data.

The 4G EU gateway is supported in all European countries, including UK.

ABB sim card is included in the gateway. No customer sim card is required.

Connected Services 4G US [890-7]

The option *Mobile network 4G EU* for Connected Services uses a 4G mobile network connection for transferring data.

The 4G US gateway is supported in USA and Canada.

ABB sim card is included in the gateway. No customer sim card is required.

2 Specification of variants and options

2.3 FlexPendant

2.3 FlexPendant

FlexPendant [701]

Teach pendant with touch screen. For more information see *Operating manual - IRC5 with FlexPendant*.



Option	Description
701-1	FlexPendant 10 m including mounting kit.
701-3	FlexPendant 30 m With this option the FlexPendant will be delivered with the longer cable assembled from factory.

The FlexPendant is available in different versions, as the hardware has been updated over the years. The exact appearance on the graphics might therefore differ slightly from reality.

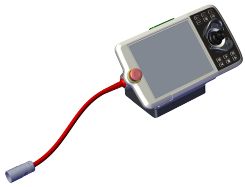

Note

The different versions support many, but not all, versions of the IRC5 controllers/RobotWare versions. Contact your local ABB office for more information about compatibility.

FlexPendant with emergency stop button at the connector	FlexPendant with emergency stop button at the outer edge
 xx2100001802	 xx0300000449

Continues on next page

Mounting kit

The mounting kit includes parts for the FlexPendant holder.

The FlexPendant holder is available in different versions, that fit different FlexPendant versions. The holder is compatible with the FlexPendant that it is delivered with.

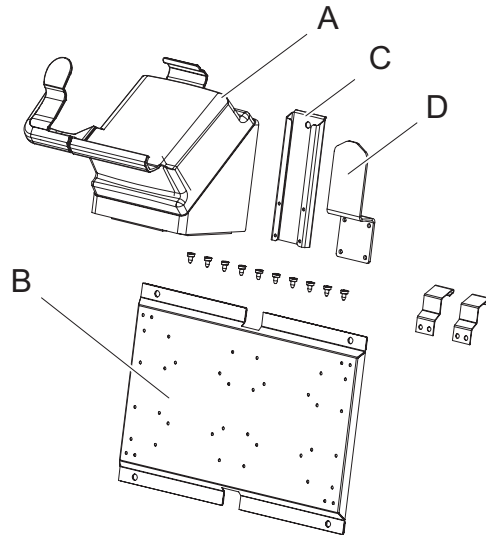

xx2200001447

A	FlexPendant holder (the appearance depends on the version of the FlexPendant)
B	Mounting plate (mounting holes \varnothing 8.5 mm (2x), distance 340 mm)
C	Cable bracket holder
D	Cable bracket

FlexPendant Extension [784]



Note

Not together with: External Operator's panel [733-3, 733-4]

Option	Description
784-1	Extension Cable 15 m
784-2	Extension Cable 22 m
784-3	Extension Cable 30 m

The extension cables are compatible with all versions of the FlexPendant.

2 Specification of variants and options

2.4 Control module

2.4 Control module

RS232 Serial channel [970-1]

One RS232 serial channel for permanent use which can be used for communication point to point with printers, terminals, computers, and other equipment.

The fieldbus adapter and the RS232 serial channel is located on the fieldbus adapter expansion board. Therefore the option 970-1 is required when using a fieldbus adapter.

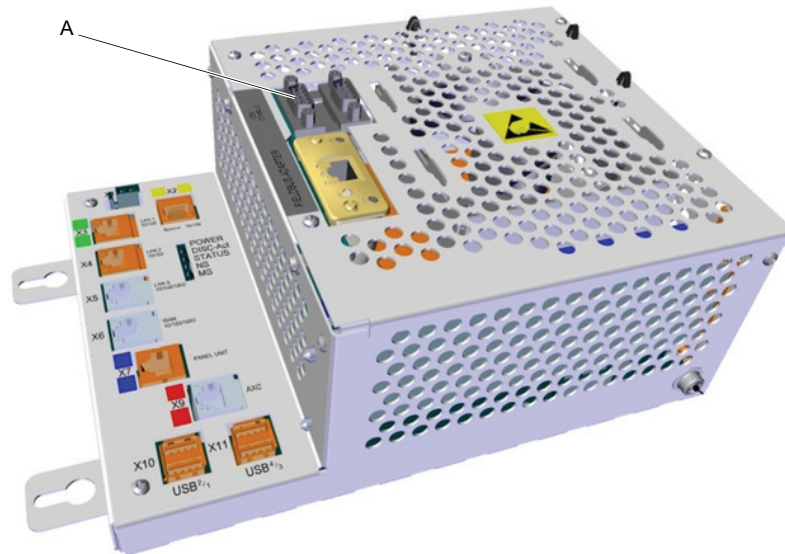

xx160000232

A	RS232 serial port
---	-------------------

Connector plug [702-1]

The option consists of a jumper connector to close the safety chains (E-stop) when to disconnect the FlexPendant. Available also with remote operator's panel.

Disconnection stops the robot.



Note

Mandatory when FlexPendant is not selected:

- enables storing of the FlexPendant away from dirty environment
- enables one FlexPendant for several robots

Hot plug [702-2]

The option consists of contacts which temporarily can override the E-stop. For permanent jumpering a connector plug 702-1 is included, also available on remote operator's panel (except Compact).

The FlexPendant can be disconnected and reconnected without affecting the program execution.

- enables storing of the FlexPendant away from dirty environment

Continues on next page

- enables one FlexPendant for several robots

2 Specification of variants and options

2.4.1 PCI options

2.4.1 PCI options

DeviceNet™ m/s [709-1]

DeviceNet is a communications link to connect industrial devices. It is a simple networking solution that reduces both cost and time to wire and install industrial automation devices, and the direct connectivity provides improved communication between devices. DeviceNet is an open network standard.

Here are some examples of applications:

- Peer-to-peer data exchange where a DeviceNet product can produce and consume messages
- Scanner/Adapter operation defined as a proper subset of Peer-to-Peer
- A DeviceNet product can function as a client or server, or both

PROFIENERGY [963-1]

PROFIenergy is a profile of the PROFINET communications protocol that allows the power consumption of automation equipment in manufacturing (such as robot assembly cells, laser cutters and sub-systems such as paint lines) to be managed over a PROFINET network. It offers an open and standardized means of controlling energy usage during planned and unplanned breaks in production. PROFINET is an open standard for Industrial Ethernet.

PROFINET satisfies requirements for automation technology. PROFINET solutions can be implemented for factory and process automation, for safety applications, and for the entire range of drive technology right up to clock-synchronized motion control.

PROFINET IO

PROFINET IO m/s SW [888-2]

PROFINET is an open standard for Industrial Ethernet. PROFINET satisfies requirements for automation technology. PROFINET solutions can be implemented for factory and process automation, for safety applications, and for the entire range of drive technology right up to clock-synchronized motion control.

PROFINET has a modular design and different PROFINET communication profiles are all combinations of modular elements from the groups transmission technology, communication protocol, and application profiles.

Here are some examples of PROFINET communication profiles:

- PROFINET-IO - Distributed I/O (Remote I/O). Here, the familiar I/O view of PROFIBUS is retained, in which the user data from the field devices are periodically transmitted into the process model of the control system
- PROFINET-CBA - Based on the object-oriented modelling of technological modules. Based on the object model, machines and installations are structured in PROFINET in the form of technological modules

With this option the IRC5 Controller can act as a controller, device, or both on the PROFINET network.

Continues on next page

PROFINET IO slave SW [888-3]

PROFINET is an open standard for Industrial Ethernet. PROFINET satisfies requirements for automation technology. PROFINET solutions can be implemented for factory and process automation, for safety applications, and for the entire range of drive technology right up to clock-synchronized motion control.

PROFINET has a modular design and different PROFINET communication profiles are all combinations of modular elements from the groups transmission technology, communication protocol, and application profiles.

Here are some examples of PROFINET communication profiles:

- PROFINET-IO - Distributed I/O (Remote I/O). Here, the familiar I/O view of PROFIBUS is retained, in which the user data from the field devices are periodically transmitted into the process model of the control system
- PROFINET-CBA - Based on the object-oriented modelling of technological modules. Based on the object model, machines and installations are structured in PROFINET in the form of technological modules

With this option the IRC5 controller can only acts as a device.

Ethernet/IP™ [841-1]

EtherNet/IP is a communications link to connect industrial devices.

The EtherNet/IP (EtherNet Industrial Protocol) is managed by ODVA (Open DeviceNet Vendors Association). It is a well established industrial Ethernet communication system with good real-time capabilities. EtherNet/IP extends commercial off-the-shelf Ethernet to the CIP (Common Industrial Protocol)—the same upper-layer protocol and object model found in DeviceNet and ControlNet. CIP allows EtherNet/IP and DeviceNet system integrators and users to apply the same objects and profiles for plug-and-play interoperability among devices from multiple vendors and in multiple sub-nets. Combined, DeviceNet, ControlNet and EtherNet/IP promote transparency from sensors to the enterprise software.

Here are some examples of EtherNet/IP applications:

- Peer-to-peer data exchange where an EtherNet/IP product can produce and consume messages
- Scanner/adaptor operation defined as a proper subset of peer-to-peer
- An EtherNet/IP product can function as a client or server, or both

Ethernet switch [941-1]

Can be used for distribution and/or extension of ethernet fieldbus options such as Profinet and Ethernet IP.

Connectors on front plate

DeviceNet™ on front [730-1]

One external DeviceNet™ connector.

Corresponding customer part is not included. Brad Harrison type 1A5006-34 or ABB part number 3HAC 7811-1 is recommended.

Continues on next page

2 Specification of variants and options

2.4.1 PCI options

Continued

Ethernet RJ45 [707-1]

Internally connected to the computer LAN port.

Ethernet M12 [906-1]

Internally connected to either the EtherNet/IP™ port or the PROFINET IO port.

For more information about the Ethernet connectors on the main computer, see [Ethernet connections on page 60](#).

Continues on next page

Fieldbus adapters (Anybus®)

Ethernet/IP™ [840-1]

EtherNet/IP™

Up to 1024 digital inputs and 1024 digital outputs can be transferred serially to a master equipped with an EtherNet/IP™ interface. The bus cable is connected directly to the adapter RJ45 connector.

For more information see *Application manual - EtherNet/IP Anybus Adapter*.

PROFIBUS DP [840-2]

PROFIBUS DP

Up to 512 digital inputs and 512 digital outputs can be transferred serially to a master equipped with a PROFIBUS DP interface. The bus cable is connected to the adapter D-sub connector.

For more information see *Application manual - PROFIBUS Anybus Device*.

PROFINET IO [840-3]

PROFINET IO

Up to 1024 digital inputs and 1024 digital outputs can be transferred serially to a master equipped with a PROFINET IO interface. The bus cable is connected to the adapter RJ45 connector.

For more information see *Application manual - PROFINET Anybus Device*.

DeviceNet IO [840-4]

DeviceNet IO

Max 512 bytes of I/O data.

Baudrate 125-500 kbit autodetect.

For more information see *Application manual - DeviceNet Anybus Slave*.

2 Specification of variants and options

2.4.2 Scalable I/O

2.4.2 Scalable I/O

Scalable I/O Internal

Base Dig. 16In/16Out [1541-1]

DSQC1030 Base unit

24 V Digital with 16 Inputs, 16 Outputs

For more information see [Scalable I/O on page 68](#)

Add-on Dig. 16In/16Out [1542-1]

DSQC1031

24 V Digital with 16 Inputs, 16 Outputs

For more information see [Scalable I/O on page 68](#)

Add-on Analog 4In/4Out [1543-1]

DSQC1032

4 Analog Inputs 4 Analog Outputs

For more information see [Scalable I/O on page 68](#)

Add-on Relay 8In/8Out [1544-1]

DSQC1033

8 Digital inputs 8 Relay outputs

For more information see [Scalable I/O on page 68](#)

Scalable I/O External

Base Dig. 16In/16Out [1541-2]

DSQC1030 Base unit

24 V Digital with 16 Inputs, 16 Outputs

For more information see [Scalable I/O on page 68](#)

Add-on Dig. 16In/16Out [1542-2]

DSQC1031

24 V Digital with 16 Inputs, 16 Outputs

For more information see [Scalable I/O on page 68](#)

Add-on Analog 4In/4Out [1543-2]

DSQC1032

4 Analog Inputs 4 Analog Outputs

For more information see [Scalable I/O on page 68](#)

Add-on Relay 8In/8Out [1544-2]

DSQC1033

8 Digital inputs 8 Relay outputs

For more information see [Scalable I/O on page 68](#)

2.4.3 Conveyor

Conv.Tracking unit Int. [1550-1]

Encoder interface unit for conveyor tracking (DSQC2000). This network based conveyor interface provides connections for 4 encoders and 8 cameras. Network communication is used to share conveyor speed and position data with one or more robot controllers. It can be located inside a robot controller. Each of the encoder inputs supports one 2 phase encoder. Each of the camera connections consists of one digital sync input, one 24V digital trigger output and a camera power output. The camera connection may also be used for other kind of sync input sources like eg. photocells.

This option is required for:

- Conveyor Tracking (RW option 606-1) which makes the robot follow a work object on a moving conveyor
- PickMaster conveyor tracking applications

General	
Power supply input	24 VDC (-15/+20%), typically 200 mA (Current not including power outputs)
Operating temperature	+5°C - +65°C
Ethernet LAN	2 switched LAN ports, 100Mbit (Normally not used)
Ethernet WAN	1 WAN port, 100Mbit

Encoders	
	4 pcs (X11-X14)
Power output	24VDC, max 120 mA With connection discovery and overload protection/diagnostic (Floating pins will stay at discovery voltage of 10V at off state)
Frequency	0 - 20 kHz
Input current	5.2 mA at 24 VDC
Voltage levels	15 VDC < '1' < 30 VDC, -3 VDC < '0' < 5 VDC
Supported Encoder types	PNP, NPN and Push-Pull

Following encoder is verified: Lenord & Bauer GEL 262.

Cameras	
	8 pcs (X21-X28)
Camera power Output	Supplied from X20 camera power inlet. Normally 24VDC With overload protection

Sync input Signal	
Power output	24VDC, 120 mA With overload protection
Frequency	0-20kHz
Input Current	5.2 mA at 24 VDC
Voltage levels	15 VDC < '1' < 30 VDC, -3 VDC < '0' < 5 VDC
Supported input types	PNP and Push-Pull

Continues on next page

2 Specification of variants and options

2.4.3 Conveyor Continued

Trigger output	
Digital output	24VDC , Max 120 mA With connection discovery and overload protection/diagnostic. (Floating pins will stay at discovery voltage of 10V at off state)
Minimum load	0.1 mA



Note

This option includes the software option *Tracking unit interface* [1552-1].

This option is required to support 1-4 conveyors and 1-8 object detecting sensors, e.g. cameras. This option can be shared remotely with neighboring controllers via a local network if software option *Tracking unit interface* [1552-1] is available on these controllers.

This option is possible to order with *Single cabinet* [700-3].

Requires:

- 24V [727-x]
- *Conveyor Tracking* [606-x] or *Prep. for PickMaster 3* [642-1]

Conv.Tracking unit Ext. [1551-1]

Encoder interface unit for conveyor tracking (DSQC2000) located in a suitable cabinet. See [Conv.Tracking unit Int. \[1550-1\] on page 127](#).



Note

This option includes the software option *Tracking unit interface* [1552-1].

This option is required to support 1-4 conveyors and 1-8 object detecting sensors, e.g. cameras. This option can be shared remotely with neighboring controllers via a local network if software option *Tracking unit interface* [1552-1] is available on these controllers.

This option is possible to order with Controller variants: *Single cabinet* [700-3], *Panel mounted modules* [700-5], and *Compact 2nd generation* [700-8].

Requires: *Conveyor Tracking* [606-x] or *Prep. for PickMaster 3* [642-1]

2.4.4 Internal DeviceNet I/O

Digital 24V 16In/16 Out [716-1]

Digital 24V 16In/16Out

Digital 24 VDC I/O (DSQC 652).

16 inputs/16 outputs.

Also available for external mounting, see [External DeviceNet I/O on page 130](#).

Encoder interface unit [726-1]

Encoder interface unit for conveyor tracking (DSQC 377B).

This option is required for:

- *Conveyor Tracking* (RW option 606-1) which makes the robot follow a work object on a moving conveyor.
- *Sensor Synchronization* (RW option 607-1) adjusts the robot speed to an external moving device (for example a press or conveyor) with the help of a sensor.
- *PickMaster* conveyor tracking applications.

The customer encoder and synchronization switch cables are connected directly to the DSQC 377B (one 16-pole Phoenix connector included). The encoder must be of 2 phase type for quadrature pulses, to enable registration of reverse conveyor motion, and to avoid false counts due to vibration etc. when the conveyor is not moving.

Output signal: Open collector PNP output.

Voltage: 10-30 V (normally supplied by 24 VDC from DSQC 377B).

Current: 50-100 mA.

Phase: 2 phase with 90 degree phase shift.

Duty cycle: 50%.

Following encoder is verified: Lenord & Bauer GEL 262.

CC-Link slave [723-1]

CC-Link (DSQC 378B).

Up to 176 digital inputs and 176 digital outputs can be transferred serially to a PLC equipped with an CC-Link interface. The bus cables are connected directly to the DSQC 378B (one 6-pole Phoenix connector included).

Also available for external mounting, see [CC-Link Slave External \[899-1\] on page 130](#).

2 Specification of variants and options

2.4.5 External DeviceNet I/O

2.4.5 External DeviceNet I/O

Dig 24V 16In/16Out External [816-1]

Digital 24 VDC I/O (DSQC 652).

16 inputs/16 outputs.

Also available for internal mounting.

CC-Link Slave External [899-1]

Digital 24 VDC I/O (DSQC 652).

16 inputs/16 outputs.

Also available for internal mounting.

Encoder interface unit-External [826-1]

The customer encoder and synchronization switch cables are connected directly to the DSQC 377B (one 16-pole Phoenix connector included).

The encoder must be of 2 phase type for quadrature pulses, to enable registration of reverse conveyor motion, and to avoid false counts due to vibration etc. when the conveyor is not moving.

Parameter	Description
Output signal:	Open collector PNP output
Voltage:	10 - 30 V (normally supplied by 24 VDC from DSQC 377B)
Current:	50 - 100 mA
Phase:	2 phase with 90 degree phase shift
Duty cycle:	50%
Following encoder is verified:	Lenord & Bauer GEL 262

2.4.6 Power supply

General

In combination with DeviceNet™ m/s single channel (option 709-1) and any DeviceNet™ node (for example option 716-1), the customer power supply is pre-wired in the following ways:

Single cabinet

- As standard 24 V I/O supplies the DeviceNet™ bus and is also available for general usage on door terminals XT31. Available current 1.6 - 8 A, see [I/O system on page 65](#).
- Option 727-3. 4 A is available for general usage on door terminals X31 in addition to and separated from above.
- Option 727-1. 2 x 4 A is available for general usage on door terminals XT31 in addition to and separated from above. The two outputs are parallel connected at delivery.
- Option 728-1. The 4 A DeviceNet™ unit supplies the DeviceNet™ bus.

24V 8 Amps [727-1]

24 V 8 Amps for bus and process supply.

24V 4 Amps [727-3]

24 V 4 Amps for bus and process supply.

Devicenet 24V 4 Amps [728-1]

24 V 4 Amps for bus supply. Galvanically isolated from ground.

In the normal case the Single cabinet integrated 24 V I/O supply can be used for both bus and customer I/O. The bus is then grounded at the cabinet chassis.

Single point grounding is required by ODVA (Open DeviceNet™ Vendor Association). If there is a risk for multiple grounds, for example when the bus is distributed to several places, the option 728-1 is recommended. Then the 24 V supply is isolated from ground and the bus can be single point grounded at any customer selected place.

Another reason for selecting option 728-1 is the < 100 W output, thereby fulfilling requirements for Limited Power Source class 2 from NEC. This requirement is also met by separating the outputs for the 4 A units 727-x.

Safety internal connection [731-1]

The signals are connected directly to screw terminals at the panel board inside the cabinet.

Safety external connection [731-2]

The signals are connected via a 40-pole standard industrial connector in accordance with DIN 43652.

The connector is located at the foot of the module. Corresponding customer part is included.

2 Specification of variants and options

2.4.7 Functional Safety

2.4.7 Functional Safety

Safety module [996-1]

To use the options *SafeMove Basic* and *SafeMove Pro* you need to install the Safety module DSQC1015 in the robot controller. The Safety module DSQC1015 is normally installed at delivery inside the IRC5 main computer unit.



Note

It is not possible to have the options *SafeMove Basic* or *SafeMove Pro* installed at the same time as *Electronic Position Switches* or first generation *SafeMove*.

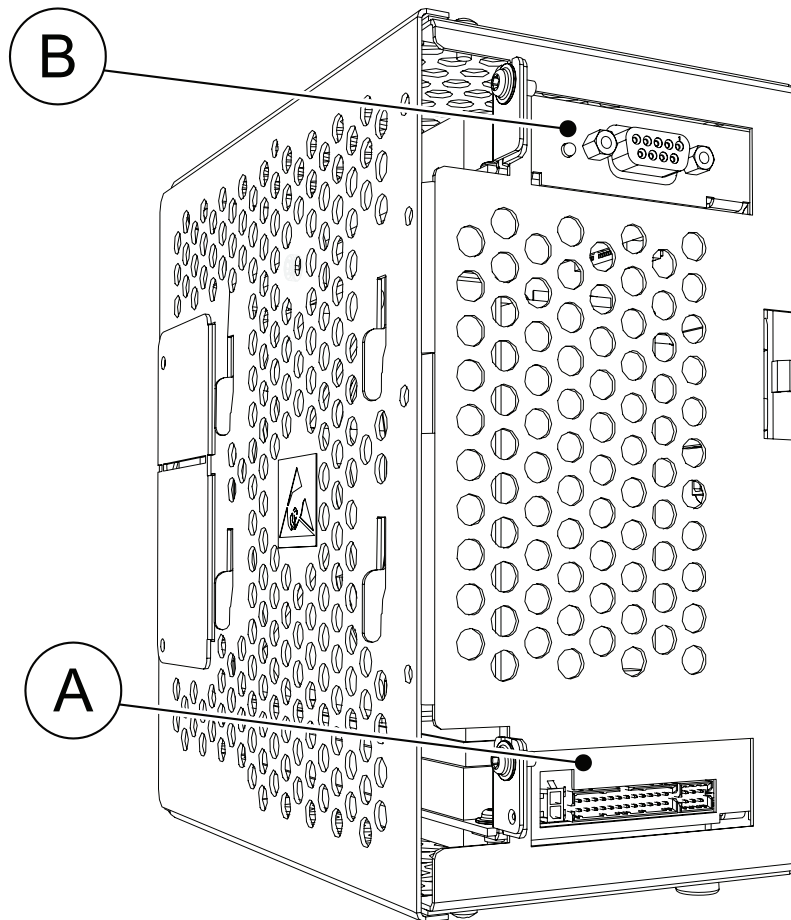

xx1500001760

A	Safety module DSQC1015
B	PCI-express slot for Safety module
C	PCI-express slot for other devices.

Continues on next page



Note

For a controller with a safety module, status signals for emergency stop can only be read from the safe fieldbus (see Application manual - Functional safety and SafeMove2).

ProfiSafe F-Device [997-1]

All I/O communication for the SafeMove functionality is done via a safety PLC using PROFIsafe (safe PROFINET). The safety PLC will act as a PROFIsafe controller (F-Host) and the IRC5 will act as a PROFIsafe device (F-Device). The PROFIsafe I/O is connected to one of the the Ethernet ports WAN, LAN 2, or LAN 3 on the main computer.

A RobotWare license with the options PROFINET Controller/Device, or PROFINET Device, and PROFIsafe F-Device are required to to run PROFIsafe on the IRC5 controller.

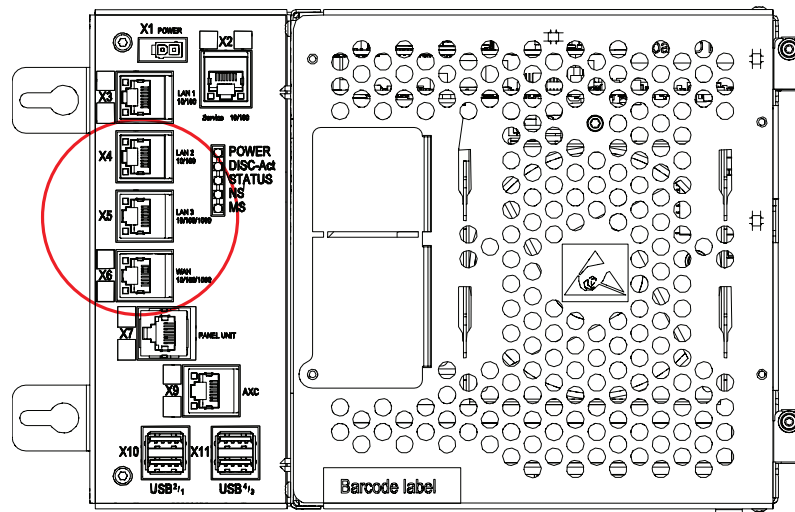

xx1300001966

X4	LAN2	Local Area Network that can host a private industrial network.
X5	LAN3	Local Area Network that can host a private industrial network.
X6	WAN	Wide Area Network that can host a public industrial network.

PROFIsafe F-Host&Device [997-2]

I/O communication for the SafeMove functionality can be done via a safety PLC using PROFIsafe (safe PROFINET). The safety PLC will act as a PROFIsafe controller (F-Host) and the IRC5 will act as a PROFIsafe device (F-Device). The PROFIsafe I/O is connected to one of the Ethernet ports WAN, LAN 2, or LAN 3 on the main computer.

In addition, using this option, it is possible to have the robot controller act as a PROFIsafe controller and host safe I/O devices (F-Devices) directly. The devices are connected to the same Ethernet ports on the main computer as described above.

Continues on next page

2 Specification of variants and options

2.4.7 Functional Safety

Continued

A RobotWare license with the options PROFINET Controller/Device and PROFIsafe F-Host&Device are required to run PROFIsafe on the IRC5 controller.

CIP Safety Adapter [997-3]

I/O communication for the SafeMove functionality is done with a safety PLC using CIP Safety (safe EtherNet/IP). The safety PLC will act as a CIP Safety controller (Scanner) and the IRC5 will act as a CIP Safety device (Adapter). The CIP Safety I/O is connected to one of the Ethernet ports WAN, LAN 2, or LAN 3 on the main computer.

A RobotWare license with the options EtherNet/IP Scanner/Adapter and CIP Safety Adapter are required to run CIP Safety on the IRC5 controller.

CIP Safety Scanner&Adap. [997-4]

I/O communication for the SafeMove functionality can be done via a safety PLC using CIP Safety (safe EtherNet/IP). The safety PLC will act as a CIP Safety Scanner and the IRC5 will act as a CIP Safety Adapter.

The CIP Safety I/O is connected to one of the Ethernet ports WAN, LAN 2, or LAN 3 on the main computer.

In addition, using this option, it is possible to have the robot controller act as a CIP Safety Scanner and scan safe I/O devices directly. The devices are connected to the same Ethernet ports on the main computer as described above.

A RobotWare license with the options EtherNet/IP Scanner/Adapter and CIP Safety Scanner&Adap are required to run CIP Safety on the IRC5 controller.

Continues on next page

2.4.7.1 Discrete I/O Safety

Prepared for ABB CI502 [1241-1]

Using this option, it is possible to have the robot controller act as a PROFIsafe controller and host safe I/O devices (F-Devices) from ABB directly. The devices are connected to one of the Ethernet ports WAN, LAN 2, or LAN 3 on the main computer. This option is using PROFIsafe, but is not a general F-Host functionality as it is locked to specific safe I/O devices from ABB (see application note *Unbundled S500 Safety I/Os 3ADR024128K0201* for more information).

A RobotWare license with the options PROFINET Controller/Device and Prepared for ABB CI502 are required to run PROFIsafe on the IRC5 controller.

2 Specification of variants and options

2.4.7.2 Safety Robot Supervision

2.4.7.2 Safety Robot Supervision

SafeMove Basic [1125-1]

The option SafeMove gives you access to the configurator **Visual SafeMove** in RobotStudio. With **Visual SafeMove** you can:

- configure and visualize supervision functions in a 3D environment
- configure stop functions, such as automatic stop
- configure *Cyclic Brake Check*
- configure safe signals (safe Ethernet communication and I/Os)
- configure signal logics
- configure system status outputs

For more information, see *Application manual - Functional safety and SafeMove2*.

Included functions	
Supported number of axes	9
Safe ranges	8
Safe zones	1
Axis Position Supervision	Yes
Contact application support	Yes

SafeMove Pro [1125-2]

The option SafeMove gives you access to the configurator **Visual SafeMove** in RobotStudio. With **Visual SafeMove** you can:

- configure and visualize supervision functions in a 3D environment
- configure stop functions, such as automatic stop
- configure *Cyclic Brake Check*
- configure safe signals (safe Ethernet communication and I/Os)
- configure signal logics
- configure system status outputs

For more information, see *Application manual - Functional safety and SafeMove2*.

Included functions	
Supported number of axes	9
Safe ranges	8
Safe zones	16
Tool changer support	Yes (16 tools)
Axis Position Supervision	Yes
Axis Speed Supervision	Yes
Tool Orientation Supervision	Yes
Tool Position Supervision	Yes
Tool Speed Supervision	Yes
Stand Still Supervision	Yes

Continues on next page

2 Specification of variants and options

2.4.7.2 Safety Robot Supervision

Continued

Included functions	
Contact application support	Yes

2 Specification of variants and options

2.4.8 IMM Interface

2.4.8 IMM Interface

General

IMM (Injection Mould Machines) interface. The Euromap (European Committee of Machinery Manufacturers for the Plastics and Rubber Industries) and SPI (Society of Plastics Industry) options are the injection moulding machine – robot signal interface.

The two different options are based on the European and the American standards.

Connection

Euromap 67 and SPI AN146 [671-2]

This is the standard in Europe, which offers double channel security from the injection moulding machine. The robot interface for Europe 67 is implemented in the standard IRC5 cabinet with a Euromap connector mounted on the connector plate.

For additional information see [Further options](#)

Cable [673]

Option	Description
673-1	Cable 10m
673-2	Cable 15m

Further options

The Euromap/SPI options require the following options to be ordered with the robot:

- For 671-2, 1 Scalable I/O module, Base Dig. 16In/16Out [1541-1]
- For additional devices such as gripper, conveyor, additional Scalable I/O modules may be needed

To configure the Euromap/SPI input and output signals in the RobotWare, I/O-configuration files are available in the RobotWare installation in the folder *Utility*. In robot test mode, when the machine is disconnected, the controller jumper plug

Continues on next page

can be used. The Euromap/SPI options are compatible with application software *RW Machine Tending*, [1167-1].

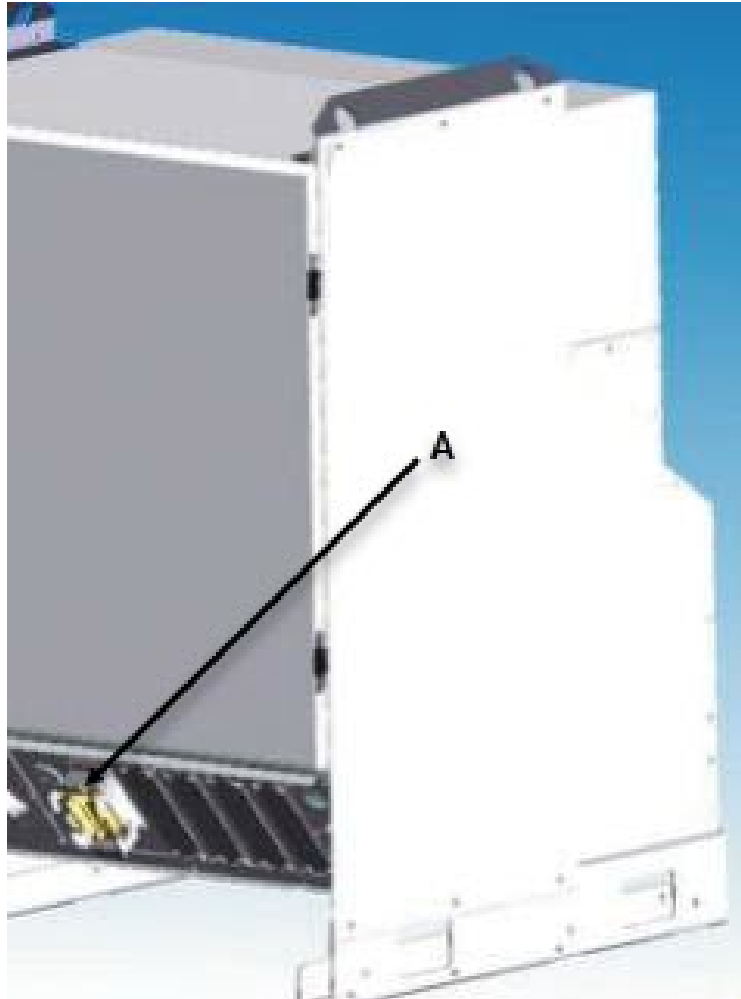

xx0900000978

A	Option 671-2, Euromap 67
---	--------------------------

2 Specification of variants and options

2.4.9 Operator's interface

2.4.9 Operator's interface

Operators panel

General

External operator's panels can be either simply a panel or a panel box. See illustrations below.



Note

When ordering the external operator's panel as an add-on, the external operator's panel is delivered empty together with labels and blanking plugs. When installing, the following components must be moved from the controller to the external operator's panel:

- Mode switch
- Motor ON button
- Emergency stop button

Panel on cabinet [733-1]

Panel in the front of the cabinet (standard)

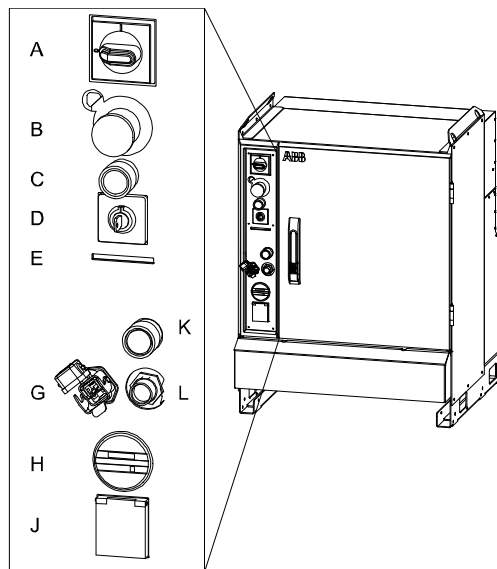

xx0600002782

Continues on next page

External panel [733-3]

To be mounted in a separate operator's unit (enclosure not supplied). See installation requirements in the figure below.

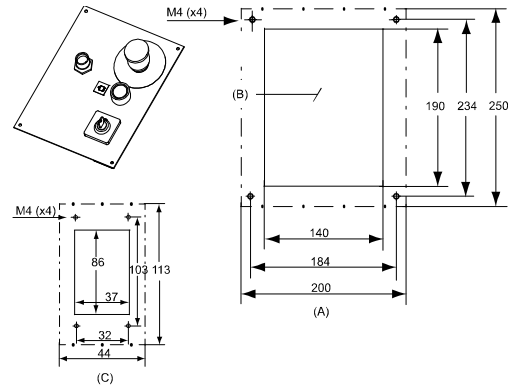

xx090000984

A	Holes for operator panel
B	Required depth 130 mm
C	Holes for cable flange

External panel small box [733-4]

Operator's panel mounted in a box. See figure below

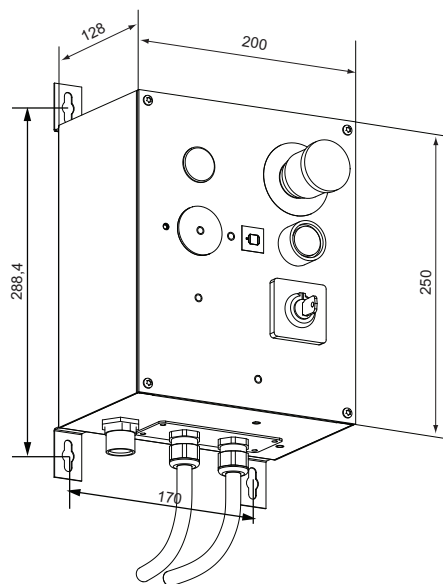

xx110000562

Operator's panel cable

Option	Description
734-1	Panel cable - 15 m
734-3	Panel cable - 30 m
734-5	Panel cable - 7 m

Continues on next page

2 Specification of variants and options

2.4.9 Operator's interface

Continued

Operating mode selector (key switch) [735]

Option	Standard	Description
735-1	Standard	Three modes: manual, manual full speed and automatic.
735-2	Standard	Two modes: manual and automatic.
735-3	Additional contact	Three modes manual, manual full speed and automatic.
735-4	Additional contact	Two modes: manual and automatic.
735-7 735-8	Keyless Mode Selector	<p>Three modes Two modes</p> <p>Operator mode selection from the FlexPendant without key switch.</p> <p>For more information, see <i>Application manual - Functional safety and SafeMove2</i>.</p> <p> Note</p> <p>Cannot be combined with option 733-X External Panel.</p>

The three mode types do not comply with UL safety standards, since manual full speed is not permitted. The option additional contact means contacts (dual channels) for customer usage, see Figure below. The connector S21.1.X1 is found in the cable harness. Customer part is included.

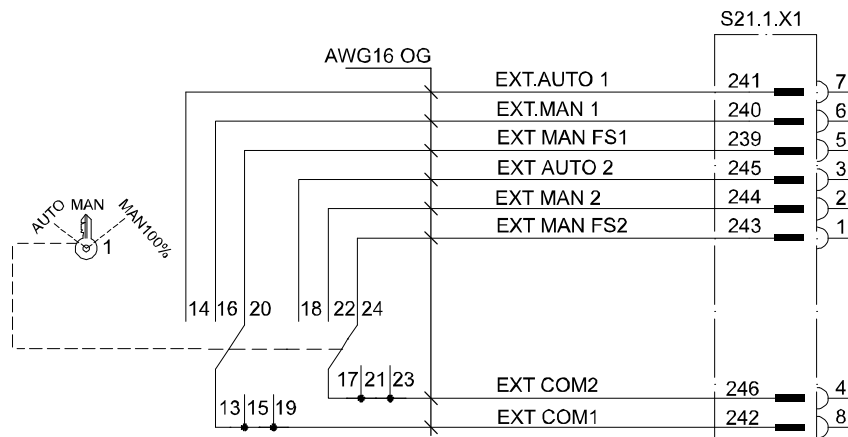

xx0900001033

As standard the mode selector position can be indicated by relay contacts (single channel), see figure below. The connector X15 is located at the panel board (see option 731-1). Customer part is not included. Recommended type ABB CEWE Control, article number 1SSA 445024 R0100.

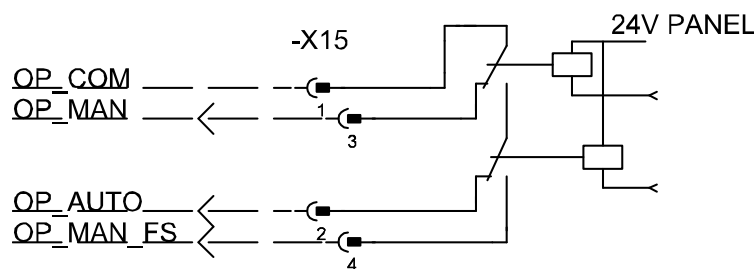

xx0900000982

Continues on next page

Safety chain status LEDs at front [737-1]

Select this option when:

- to avoid opening the door
- you need a rapid way to check status regardless of actual FlexPendant window

2 Specification of variants and options

2.5 Drive module

2.5 Drive module

Single drive unit [907-1]

Single drive unit (maximum three), Drive unit ADU-790A

Drive unit type	Rated current (Amp rms)	Max current (Amp rms)	Voltage to motor (V rms)
ADU-790A	30	55	377-430 ⁱ , 234

ⁱ Depending on line voltage, when used in IRB 66XX/7600

Prepared for Trackmotion [981-1]

Option 981-1 opens up for combinations of external drives for Trackmotion, Positioners. Motor units and Servo Gun.

Three identical connections for:

- External brake release
- External brake release push button
- PTC2

External connectors for:

- XS7
- XS 101/102



Note

Important electric changes:

- Lim2 removed from XS7 connection
- 0V Brake on axis selector is no longer from PTC2 0V

Prepared for Positioners [922-1]

The option makes it possible to link IRBP X-list with IRB X-list in BOL. Drive units 907-1 should not be selected in the IRB X-list. The number will be pre-selected depending of type of positioner.



Note

Exception! If the IRBP is ordered outside BOL the drive units must be selected in the IRB X-list



Note

The harnesses XS41/XS41.2 are needed to connect the robot controller with the positioner. To get the harness with connectors XS41/XS41.2 on the robot controller, the option *922-1 Prepared for IRBP* has to be booked and the positioner type must be specified.

Continues on next page

Prepared for Motor unit/Gear unit [946-1]

This option prepares the IRC5 controller to be possible to connect Motor units and Gear units.

This option makes it possible to link Motor units and Gear units X-list with IRB X-list in BOL.



Note

Drive units must be selected in the IRB X-list.

This option also:

- contains a side bracket for MU/GU axis selector lock
- Replaces motor power connector XS7 by XS101 if MUGU is ordered together with a robot system order
- The cable harness in the cabinet is generated from the MUGU order and it will be delivered assembled from factory if the MUGU is ordered together with a robot system order
- Blocks servo gun in BOL

Continues on next page

2 Specification of variants and options

2.5 Drive module

Continued

Prep. for 3rd party MU [1389-1]

The option *Prep. for 3rd party MU* prepares IRC5 controller to be possible to connect 3rd party MU to the controller.

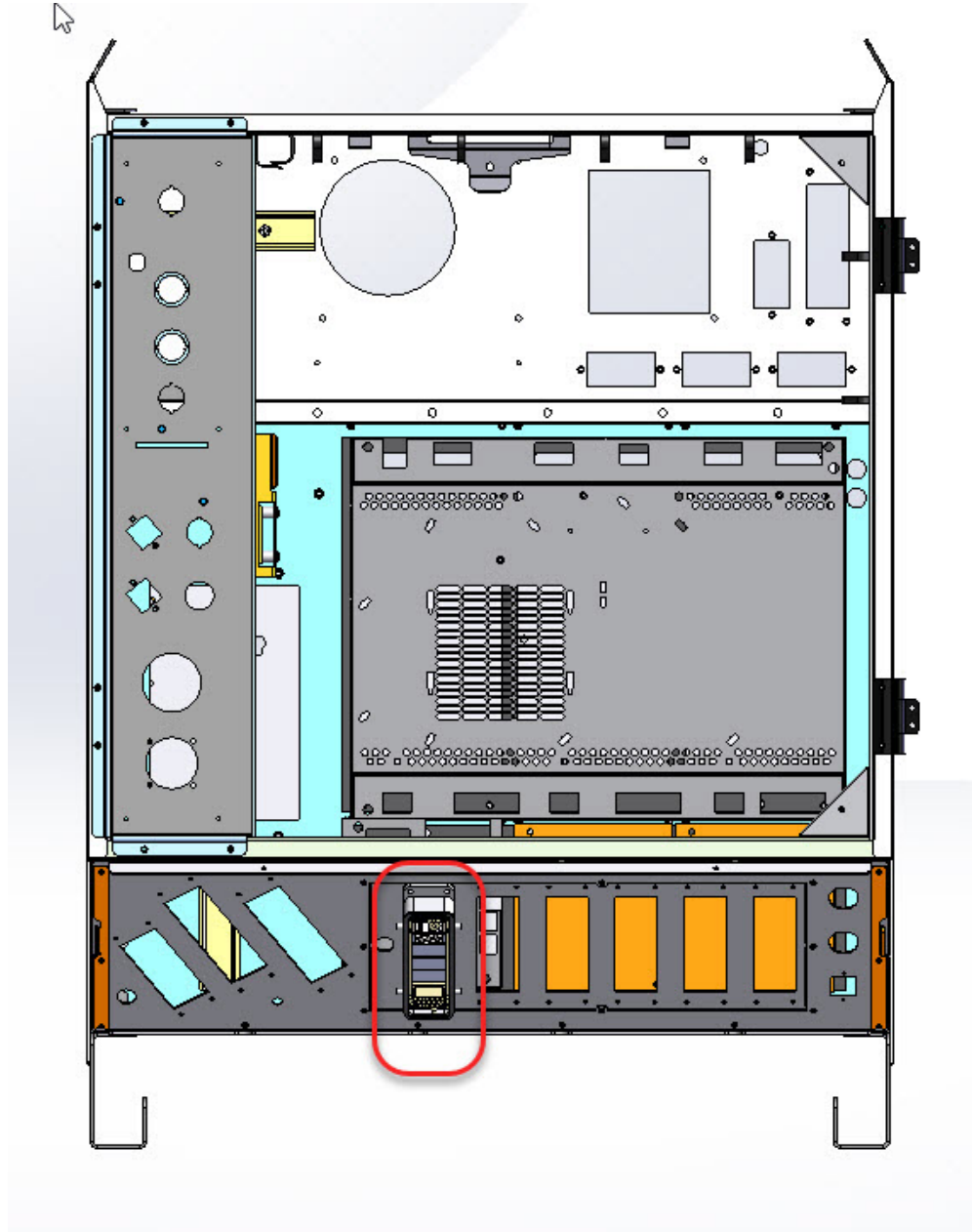

xx2000002428

Continues on next page

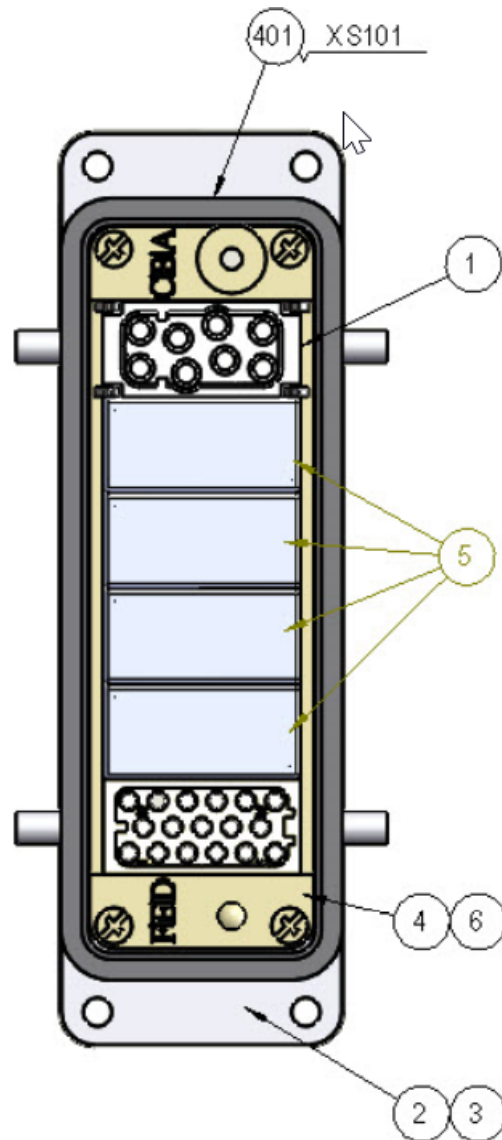

xx2000002429

1	Harness Drive unit
2	Adapter bulkhead mounting
3	Gasket
4	Hinged frame hood A_F
5	Module Dummy
6	Lock frame A-F
7	Earth cable XS101/XS102

Requirements:

The option requires 1 unit of Single drive unit [907-1].

Limitations:

The option is not possible to order with the options below:

- Prepared for MU/GU [946-1]

Continues on next page

2 Specification of variants and options

2.5 Drive module

Continued

- Controller variants: *Panel mounted modules* [700-5], *Panel mounted drive only* [700-6], *Compact 2nd generation* [700-8]
 - NOT TOGETHER with Cable [786-x]
-

SMB for additional motors

External SMB unit [757-1]

This option is selected when having customer designed equipment.

Contains:

- Serial measurement board as separate unit with battery.

External SMB unit with cables [757-2]

This option is selected when having customer designed equipment.

Contains:

- serial measurement board as separate unit with battery
- one 700 mm cable with connector fitting the measurement link 1400 mm
- one cable with a 64-pole industrial female connector for resolver connection

Continues on next page

2.5.1 Drive module options

Additional cables [761]

These options are intended for distributed drive modules, see examples below.

Option	Description
761-1	Drive module cables 4m
761-3	Drive module cables 30m

Example with option 761-1

Drive module only (700-1) with 4 m cable. The combination is intended for stacking with single cabinet. The option consists of Ethernet and safety cables (2 pcs). One cable duct is included but not mounted.

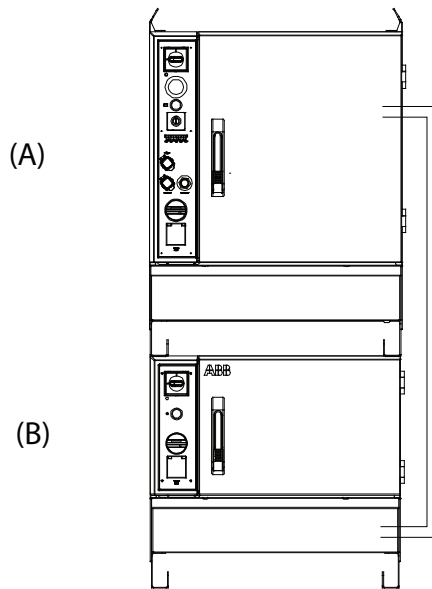

xx130000794

A	Single cabinet
B	Drive module

Example with option 761-3

Drive module only (700-1) with 30 m cable for distributed layout. The option consists of Ethernet and safety cables (2 pcs). Cable duct is not included.

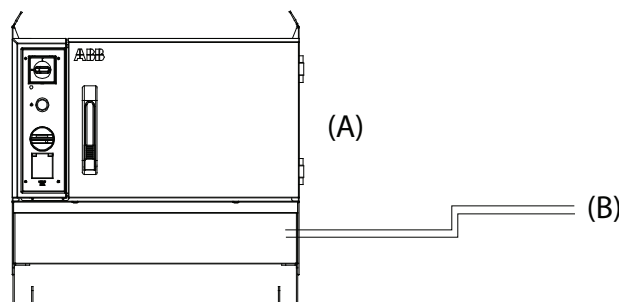

xx130000795

Continues on next page

2 Specification of variants and options

2.5.1 Drive module options

Continued

A	Drive module
B	To single cabinet

Duty Time Counter [767-1]

Indicates the operating time for the manipulator (released brakes)

In addition to the optional hardware duty time counter (DTC) there is also a software DTC included in SIS (*Service Information System*).

This function displays the operating time on the FlexPendant. To read the software DTC tap *ABB menu/System Info/Hardware devices/Mechanical units/ROB_1/General SIS data*.

For more information, see *Operating manual - Service Information System*.

Wheels [758-1]

The cabinet foot can be equipped with wheels. Three wheels on each side with the middle wheel raised 5 mm. By balancing on the middle wheels the cabinet can easily be maneuvered. The cabinet resting position is on the front and middle wheels.

Service outlet

Service outlet 230V [736-1]

230 V outlet in accordance with DIN VDE 0620. Single socket suitable for EU countries.



Note

The outlet is equipped with earth fault protection. Max load is 200 W. The outlet is located at the front.

Service outlet 120V [736-2]

120 V outlet in accordance with American standard. Single socket, Harvey Hubble.



Note

The outlet is equipped with earth fault protection. Max load is 200 W. The outlet is located at the front.

Prepared for Force Control [738-1]

For robots which will be equipped with a force sensor by the integrator. A voltage measurement board, is encapsulated in a box to be mounted close to the manipulator.

The box is connected to the axis computer measurement link 2 with a cable of same length as option 210-x.

The option *Force control package 636-x* contains all required hardware and software to run the robot in force control mode.

See [Force control package \[636\] on page 152](#).

Continues on next page

Position supervision computer

Electronic position switch (EPS) [810-1]

A safety enabled separate computer located behind the axis computer.

This option can be selected for several reasons:

- Replacing mechanical switches
- Fully integrated in cabinet
- Maintenance free
- Increased flexibility
- Easy to set up
- Easy to replace a robot in production
- Enabling more compact mechanical units
- Suitable in dirty environment

SafeMove [810-2]

SafeMove is a safety controller in the robot system. The purpose of the safety controller is to ensure a high safety level in the robot system using supervision functions that can stop the robot and monitoring functions that can set safe digital output signals.

The supervision functions can be activated by safe digital input signals. Both input and output signals can be connected to, for instance, a safety PLC that can control which behavior is allowed for the robot at different times.

The safety controller also sends status signals to the main computer, that is the standard IRC5 robot controller.

Note that *SafeMove* is one component in a cell safety system, normally complemented by other equipment, e.g. light barriers, for detecting the whereabouts of the operator.

Some examples of applications:

- Manual loading of gripper
- Manual inspection in robot cell during operation
- Optimization of cell size
- Protection of sensitive equipment
- Ensuring safe orientation of emitting processes

2 Specification of variants and options

2.6 RobotWare

2.6 RobotWare

DispensePac support [901-1]

With DispensePac support hardware and software functions can be ordered as options when buying the robot. The intention of the DispensePac support is to supply building blocks supporting the complete Dispense Package that is offered via the ABB Global Lead center. For further information on DispensePac support, see *Application manual - Dispense*.

Process Interface board (PIB) with IPS software. Ethernet Communication cables. Ethernet switch. Power supply of PIB and switch. Two DeviceNet™ cables from PIB to cabinet floor. PIB communication software. RW Dispense adaptations for DispensePac support. Paint Medium package options including Production management is available in System Builder (RobotStudio).

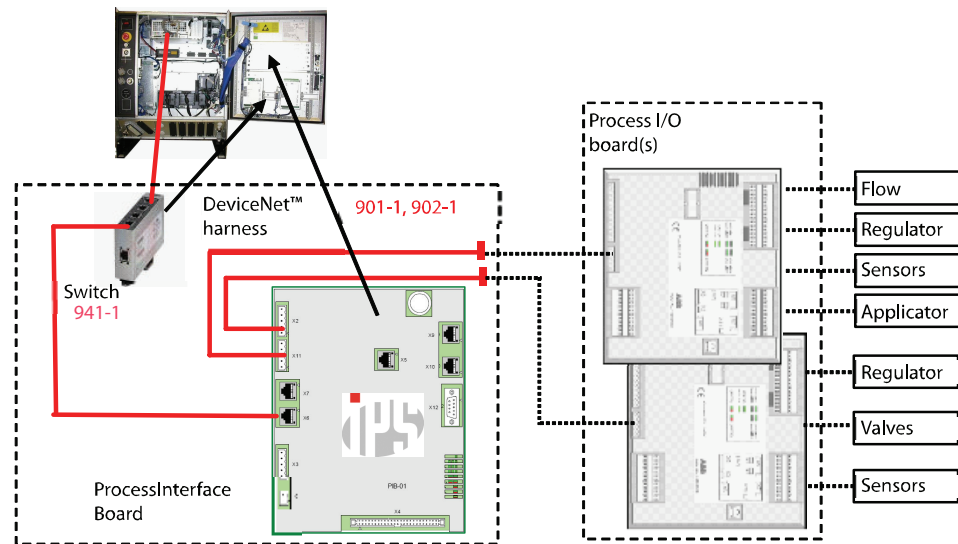

xx0900000965

Channel support [902-1]

Defines number of control loops (1 - 5 to specify).

Force control package [636]

The force control package contains all required hardware and software to run the robot in force control mode.

It contains the following components:

- Option 738-1 Prepared for Force Control.
See [Prepared for Force Control \[738-1\] on page 150](#).
- Option 661-2 Force Control Base
- Force sensor, adapter plate and cabling as described below.

Option	Description
636-1	Force Control Package 165
636-2	Force Control Package 660

Continues on next page

Option	Description
636-3	Force Control Package 2500

The integrated force sensor can be mounted on the robot flange using an adaptor plate. The force sensor can also be stationary mounted. A cable is supplied to connect the force sensor to the voltage measurement board. Cable management must be arranged by the user.

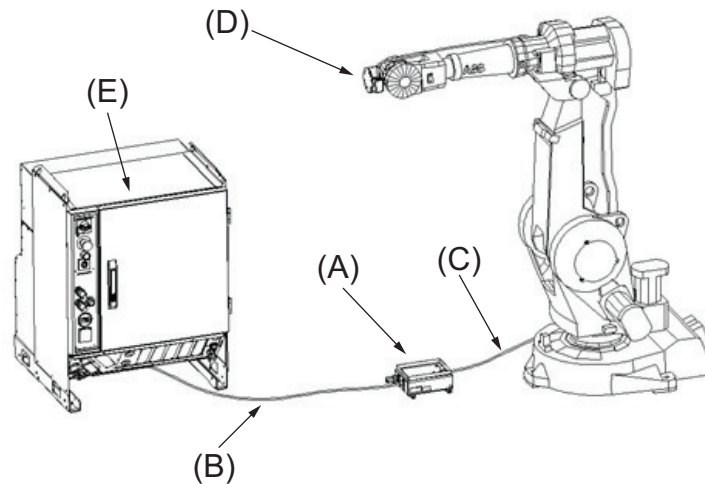

xx130000204

A	Voltage measurement board (option 738-1, Prepared for Force Control)
B	Cable between robot controller and voltage measurement board
C	Cable between force sensor and voltage measurement board
D	Force sensor, including adaptor plate and calibration information
E	Force Control software (option 661-2 Force Control Base)

The force sensor measures all six components of force (F_x , F_y and F_z) and torque (M_x , M_y and M_z).

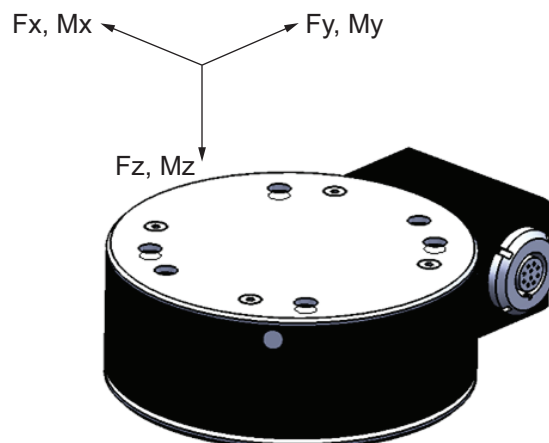

xx130000205

Continues on next page

2 Specification of variants and options

2.6 RobotWare

Continued

Force sensor dimensions

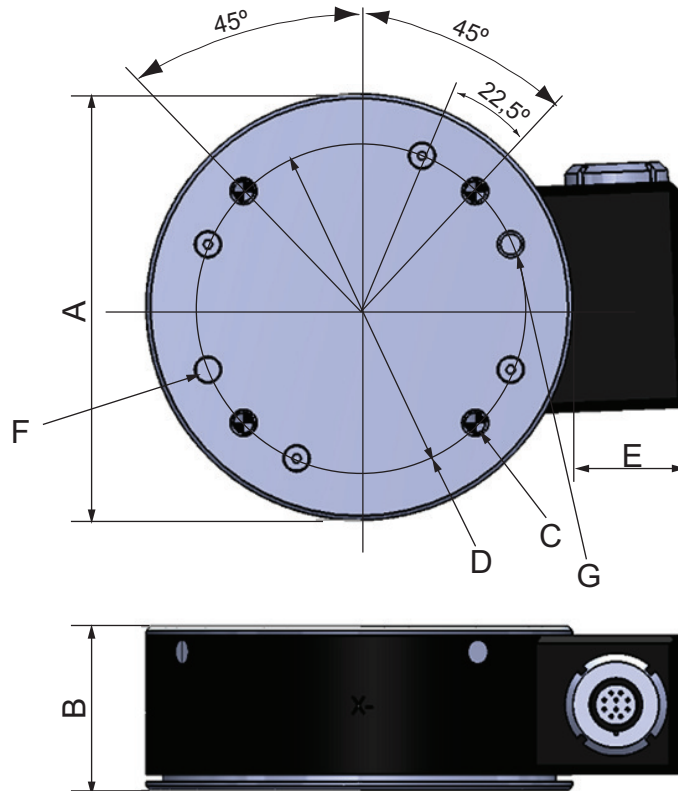

xx130000206

	Sensor package 165 and 660	Sensor package 2500
A	Diameter 104 mm	Diameter 168 mm
B	Height 40 mm	Height 62 mm
C	4 x M6 Min. thread length is 7.6 mm (on both sides)	4 x M10 Min. thread length is 15 mm (on both sides)
D	Diameter 80 mm	Diameter 124 mm
E	27 mm	27 mm
F	Diameter $6.02^{+0.02}$, depth min. 7 mm (on both sides)	Diameter $8.02^{+0.02}$, depth min. 9 mm (on both sides)
G	Diameter $5.02^{+0.02}$, depth min. 7 mm (on both sides)	Diameter $10.02^{+0.02}$, depth min. 9 mm (on both sides)

Continues on next page

Adaptor plate dimensions

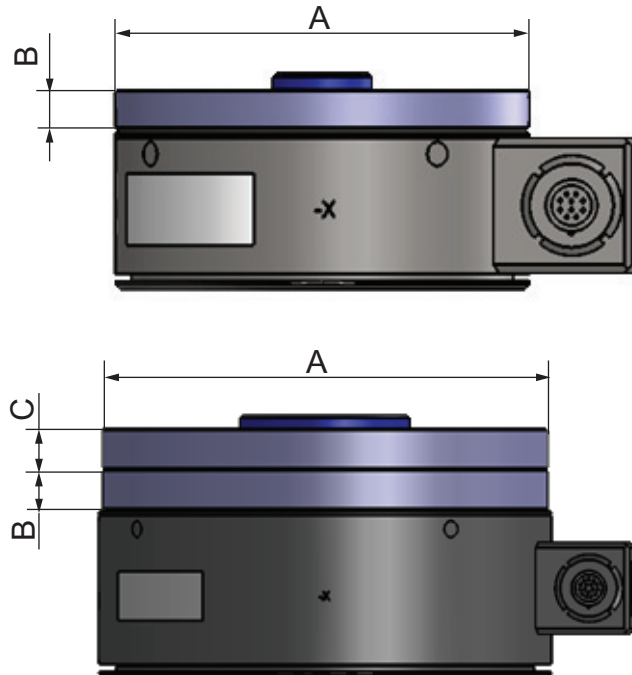

xx1300000207

	Sensor pack- age 165	Sensor package 660		Sensor package 2,500	
		Ø 104 mm	Ø 104 mm	Ø 140 mm	Ø 165 mm
A	Ø 104 mm	Ø 104 mm	Ø 140 mm	Ø 165 mm	Ø 210 mm
B	10 mm	10 mm	10 mm	15 mm	15 mm
C	-	-	15 mm	15 mm	20 mm
Type	Single adapter	Single adapter	Double ad- apters	Double adapters	
Weight (B + C)	0.6 kg	0.6 kg	1.1 + 1.7 kg	2.3 + 2.5 kg	3.8 + 5.3 kg
Suitable robots	IRB 1200 IRB 1600 IRB 2400 IRB 2600	IRB 2400 IRB 2600	IRB 4400 IRB 4600	IRB 4400 IRB 4600	IRB 6620 IRB 6640 IRB 6650S IRB 6660 IRB 6700



Note

Note that the adaptor plate and force sensor will generate an offset and additional weight on the tool flange, and hence affect the available payload of the robot. Please refer to the robot load diagram for respective robot.

Continues on next page

2 Specification of variants and options

2.6 RobotWare

Continued

Force sensor specification

	Sensor package 165	Sensor package 660	Sensor package 2500
Capacity:			
Fx, Fy	165 N	660 N	2,500 N
Fz	495 N	1,980 N	6,250 N
Mx, My, Mz	15 Nm	60 Nm	400 Nm
Resolution:			
Fx, Fy	0.03	0.09	0.33
Fz	0.11	0.33	1
Mx, My, Mz	0.003	0.008	0.053
Overload capacity:			
Fx, Fy	1,650 N	6,600 N	25,000 N
Fz	4,950 N	19,800 N	62,500 N
Mx, My, Mz	150 Nm	600 Nm	4,000 Nm
Operating temperature	-40 to +100 °C	-40 to +100 °C	-40 to +100 °C
IP rating	IP65	IP65	IP65
Sensor weight	1.6 kg	1.7 kg	7.2 kg

2.7 Floor cables

General

Additional floor cables for SpotPack options, see product specification for manipulator.

Manipulator cable length

Option	Lengths
210-2	7 m
210-3	15 m
210-4	22 m
210-5	30 m

This page is intentionally left blank

Index

A

additional axes, 91, 98–99
work area limitations, 99

C

cabinets supported by SafeMove, 91, 97
category 3, 49
CCF, 49
CIP, 123
Common Cause Failures, 49
ControlNet, 123

D

DC, 49
deactivation, 92, 100
DeviceNet, 123
Diagnostic Coverage, 49

E

electronically linked motors, 100
emergency stop button
FlexPendant, 73
enabling device, 74
EN ISO 13849-1, 49, 52
external axes, combined, 99

F

full load current, 55

G

gantry, 99

I

independent joint, 92, 100
ISO 13849-1, 49

L

limit switch override, 92

M

MTTF_D, 49–51

N

non ABB additional axes, 99

O

ODVA, 123

P

performance level, PL, 49
PFH_D, 52
PL, performance level, 49
product standards, 45
PROFenergy
description, 122

R

RAPID non motion execution, 92, 101
rated voltage, 55
required performance level, PLr, 49
reset button
location, 73–74
robots supported by SafeMove, 90, 97
robots supported by the safety module, 97

S

safety controller, 90, 94, 151
safety standards, 45
SCCR, 54
servo tool changer, 92, 100
servo welding gun, 91, 99
shared drive modules, 92, 100
short circuit current rating, 54
stand alone controller, 34, 91, 100
standards, 45
ANSI, 45
CAN, 45
EN IEC, 45
EN ISO, 45
stylus pen
location, 74
supported additional axes, 91
supported cabinets, 91, 97
supported positioners, 99
supported robots, 90, 97
supported tracks, 98

T

three-position enabling device, 74
tool changer, 92, 100
track motion, 92

U

USB port
FlexPendant, 73

W

work area for additional axes, 99



ABB AB

Robotics & Discrete Automation

S-721 68 VÄSTERÅS, Sweden

Telephone +46 10-732 50 00

ABB AS

Robotics & Discrete Automation

Nordlysvegen 7, N-4340 BRYNE, Norway

Box 265, N-4349 BRYNE, Norway

Telephone: +47 22 87 2000

ABB Engineering (Shanghai) Ltd.

Robotics & Discrete Automation

No. 4528 Kangxin Highway

PuDong New District

SHANGHAI 201319, China

Telephone: +86 21 6105 6666

ABB Inc.

Robotics & Discrete Automation

1250 Brown Road

Auburn Hills, MI 48326

USA

Telephone: +1 248 391 9000

abb.com/robotics